



Professional Engineering Consultants, P.A.

CITY OF BENTON  
DESIGN STANDARDS  
AND  
STANDARD CONSTRUCTION  
SPECIFICATIONS  
for Waterline Projects

JUNE 2005

PRELIMINARY

303 S. TOPEKA  
WICHITA, KANSAS  
67202  
316-262-2691  
FAX  
316-262-3003  
[www.pce1.com](http://www.pce1.com)  
[designserv@pce1.com](mailto:designserv@pce1.com)

WICHITA  
TOPEKA  
LAWRENCE  
PITTSBURG  
TULSA



THE CITY  
OF  
BENTON, KANSAS

STANDARD ENGINEERING DESIGN CRITERIA  
AND  
GENERAL IMPROVEMENT POLICY

OUTLINE

SECTION I - GENERAL

- Purpose
- Scope
- Variation from Design Criteria
- Compliance with Applicable Statutory Requirements
- Amendment to Standard Engineering Design Criteria
- General Development Plan

SECTION V - WATER SYSTEM CRITERIA

- General
- Waterline Materials and Design
- Trench and Backfill Requirements
- Fire Hydrants, Valves and Appurtenances
- Protection of Water Supplies
- Thrust Blocks
- Water Services

THE CITY  
OF  
BENTON, KANSAS

STANDARD ENGINEERING DESIGN CRITERIA  
AND  
GENERAL IMPROVEMENT POLICY

LIST OF FIGURES

- V-1 Protective Fill Detail
- V-2 Fire Hydrant Assembly
- V-3 Valve Assembly
- V-4 Anchored Valve Assembly
- V-5 Valve Box Detail
- V-6 Blow-Off Assembly
- V-7 Thrust Block Details
- V-8 Water Meter Box and Service Detail

## I. GENERAL

### A. Purpose

The City of Benton is striving to provide uniformity in construction efforts involving public works. To accomplish this it is important that initial design comply with established standards and specifications approved by the City. In addition to initial design, there are many construction activities which will be performed which will not require design and construction documents which must also comply with uniform City standards. The following document will serve as the standard guideline for all public works construction.

### B. Scope

This document includes design criteria and typical construction details for Waterline Systems. In addition a brief material specification will be outlined.

### C. Variation from Design Criteria

Variations will be permitted from the Standard Engineering Design Criteria and General Improvement Policy when a formal request is made to the City. The request will involve the following:

1. List any and all variations being requested.
2. Provide a justification for each variation in writing. In the case of a detail, provide a sketch or an engineered drawing indicating the modification requested.
3. Request a formal meeting with the City to discuss the suggested variation.
4. Obtain in writing an approval of the modification.

Special circumstances may be encountered where a specific item is not included in the Standard Engineering Design Criteria and General Improvement Policy. If this occurs, a formal request shall be made to the City and shall meet the requirements as shown above for a variation.

### D. Compliance with Applicable Statutory Requirements

Compliance with all Federal, State and Local Laws will be required. Where permits are required by Federal, State and Local Agencies, the Project Owner will be required to complete all filing, pay all fees, and obtain an approved permit. All information including maps, plans, specifications, etc., required to obtain an approved permit shall be provided to the City.

E. Protection of Water Supplies

Waterlines laid parallel to sanitary sewers shall maintain a minimum horizontal distance of 10 feet between the sanitary sewer and waterlines. When a waterline and sanitary sewer cross and the sanitary sewer is 2 feet or more below the waterline, no special attention is needed. At all other crossings, the waterline shall be constructed of an approved pipe material with gasketed joints. One full length pipe section shall be centered at the sanitary sewer.

F. Thrust Blocks - (See Figure V-7)

All plugs, caps, tees, and bends deflecting 11 1/4° or more shall be provided with thrust restraint. The approved method for thrust restraint will be through the use of concrete reaction backing. The concrete reaction backing shall be placed between undisturbed earth and the fitting to be restrained. The thrust restraint shall be designed to overcome the resultant force at the fitting at the test pressure of the pipe or the surge pressure, whichever is greater. As an alternate, other restraint methods may be used with prior approval from the City.

G. Water Services

Water services shall be provided for all lots that are to be serviced. All taps to water mains shall be performed with a service saddle and corporation stops. Waterlines service material shall be Type "K" copper tubing. Meter setters and meter boxes shall be provided, with meters being furnished to the City Water Department for installation. Meter boxes shall be installed 6' off the property (Right-of-way) line, within the right of way. Service lines shall typically be 3/4" or 1" for residential lots. Water services shall be bid as long services (greater than 10') or short services (less than 10').

1. Materials - The following materials and manufacturers shall apply to water service materials.
  - a. Corporation Stops - AWWA Threads  
Manufacturer - Ford or Mueller
  - b. Service Saddles - Required on all water main taps.  
Bronze with silicon bronze straps and  
Bronze nuts or 18-8 stainless steel.  
Manufacturer - McDonald or Mueller
  3. Service Tubing - AWWA 7-S-CR  
Copper tubing, Type K soft copper.
  4. Unions and Couplings - Manufacturer - Ford or Mueller.

5. Copper Setters - Manufactured for connection to copper tubing.  
Provide 9" long plastic nipple installed between meter coupling nuts.  
Provide 15" long outlet leg extension.  
Manufacturer - McDonald  
3/4" - 60-212WXTD33X15  
1" - 60-412WXTD44X15
6. Meter Boxes - ASTM D1784  
18" diameter for 3/4" services  
21" diameter (min.) for 1" services
7. Meter Rings and Lids- Cast Iron  
Manufacturer - Ford C32 or Ford C4

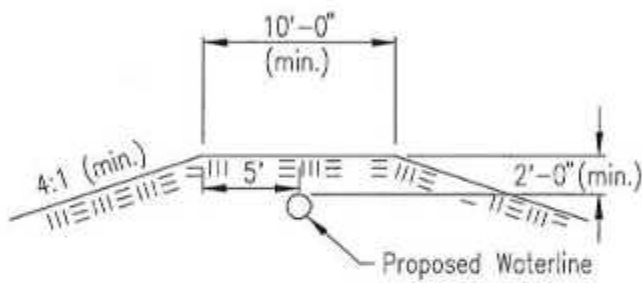

### PROTECTIVE FILL DETAIL

Minimum protective fill shall be provided in all instances where cover over the proposed waterline is less than two (2) Feet. (Cost subsidiary to pipe installation).



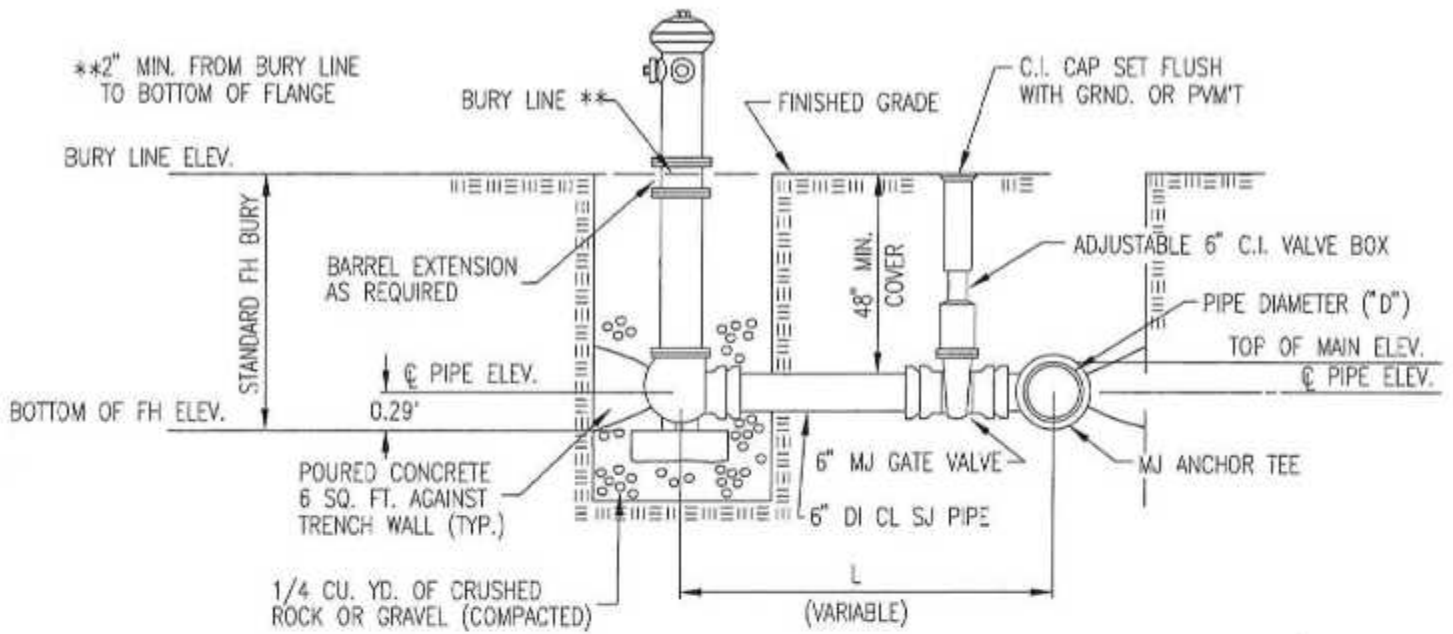

MATERIALS

- 1 - MJ Anchor Tee ("D" x 6")
- 1 - 6" MJ Gate Valve
- 1 - 6" Valve Box
- 6" DI CL SJ Pipe
- 1 - Fire Hydrant
- Concrete Blocking (As required)

FIRE HYDRANT ASSEMBLY

NOTE: ALL BLOCKING TO BE POURED CONCRETE CLASS II

FIRE HYDRANTS REQUIRED				
LINE NO.	STATION	BURY LINE ELEVATION	TOP OF PIPE ELEVATION	FIRE HYDRANT BURY REQUIRED

\* THE CONTRACTOR SHALL USE STANDARD 4.5' OR 5' FIRE HYDRANT WITH HYDRANT BARREL EXTENSIONS AS REQUIRED.

FIGURE V-2  
FIRE HYDRANT ASSEMBLY

DSNR: MOK OPER: AVY SCALE: 1=1.00  
 Q:\STANDARD\Standards Benton\water\02 05-31-2005 10:15:30 am

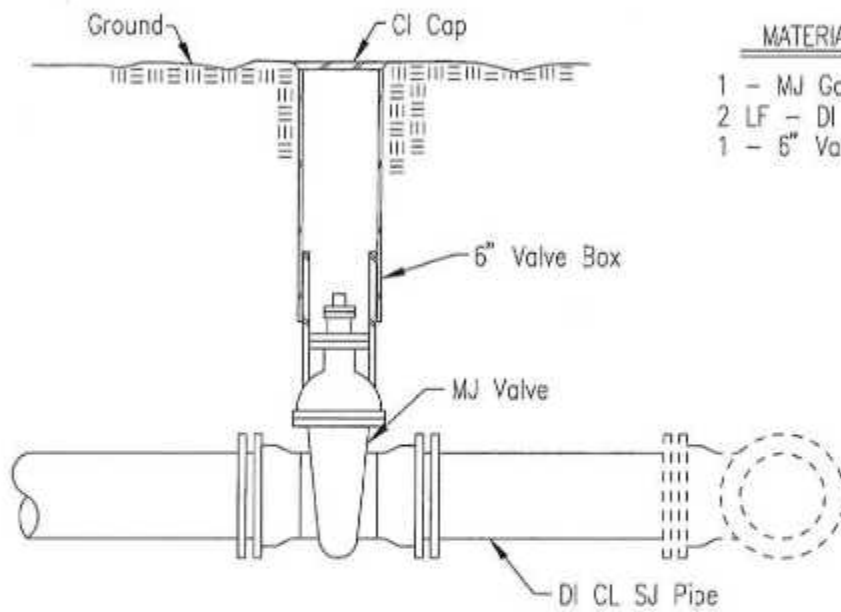

MATERIALS LIST

- 1 - MJ Gate Valve\*
- 2 LF - DI CL SJ Pipe
- 1 - 6" Valve Box

VALVE ASSEMBLY

\*See plans for size of valve to be used.

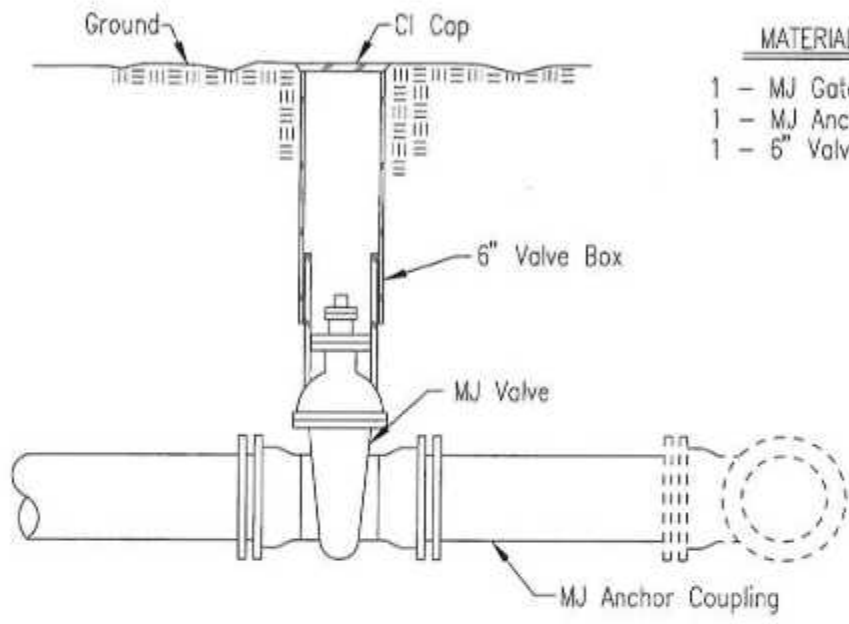

MATERIALS LIST

- 1 - MJ Gate Valve\*
- 1 - MJ Anchor Coupling
- 1 - 6" Valve Box

ANCHORED VALVE ASSEMBLY

\*See plans for size of valve to be used.

D:\SRV\_MDK\_OPER\BENTON\SCALE: 1=1.00  
 D:\STANDARD\Standards Benton\valve\V-04 05-31-2005 10:18:35 am

FIGURE V-4  
ANCHORED VALVE ASSEMBLY

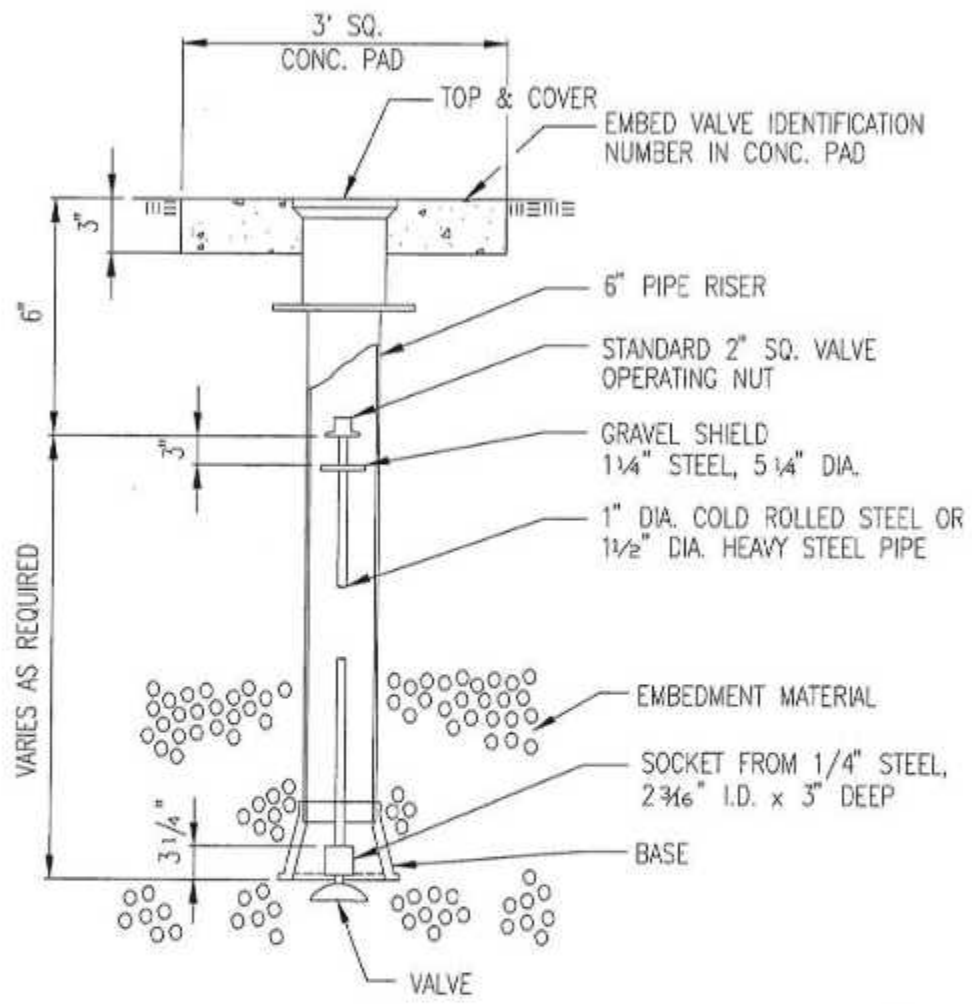

### VALVE BOX DETAIL

NOTE: ONE VALVE STEM REQUIRED FOR EACH BURIED VALVE

FIGURE V-5  
VALVE BOX DETAIL

DSHR: MDK DPER: APT SCALE: 1=1.00  
 O:\STANDARD\Standards\Benton\water\V-05 05-31-2005 10:19:12 am

## TABLE OF CONTENTS

	<u>PAGE</u>
GENERAL CONDITIONS	00700-1 - 45
SUPPLEMENTARY CONDITIONS	00800-1 - 11
SPECIFICATIONS	
DIVISION 1 - GENERAL REQUIREMENTS	
SECTION 01030 - SPECIAL PROJECT PROCEDURES	01030-1
SECTION 01040 - COORDINATION	01040-1
SECTION 01050 - FIELD ENGINEERING	01050-1
SECTION 01060 - REGULATORY	01060-1
SECTION 01100 - ALTERNATIVES	01100-1
SECTION 01150 - MEASUREMENT AND PAYMENT	01150-1 - 5
SECTION 01300 - SUBMITTALS	01300-1 - 2
SECTION 01510 - TEMPORARY UTILITIES	01510-1
SECTION 01700 - CONTRACT CLOSEOUT	01700-1
DIVISION 2 - SITE WORK	
SECTION 02001 - GENERAL	02001-1
SECTION 02100 - SITE PREPARATION	02100-1
SECTION 02200 - EARTHWORK	02200-1 - 6
SECTION 02201 - EARTHWORK - STREETS	02201-1 - 9
SECTION 02206 - EXCAVATION, TRENCHING AND BACKFILLING FOR UTILITIES	02206-1 - 7
SECTION 02221 - FLOWABLE FILL	02221-1 - 2
SECTION 02485 - SEEDING, SPRIGGING AND SODDING	02485-1 - 7
SECTION 02603 - WATER MAIN CONSTRUCTION	02603-1 - 8

## 00800 SUPPLEMENTARY CONDITIONS

The following revisions apply to the Standard General Conditions of the Contract for Construction (No. 1910-8, 1996 Edition prepared by Engineers Joint Contract Documents Committee).

Where any article, paragraph, or sub-paragraph of the General Conditions is supplemented by one of the following paragraphs, the provisions of such article, paragraph, or sub-paragraph shall remain in effect, and the supplementary provisions of such shall be considered as added thereto. Where any article is superseded by one of the following paragraphs, the provisions of such article, paragraph or sub-paragraph not so amended, voided or superseded shall remain.

1. ARTICLE 1 - DEFINITIONS - No changes, additions, or amendments.

2. ARTICLE 2 - PRELIMINARY MATTERS

2.02 Copies of Documents: A. - delete the phrase "ten copies" from the first sentence and insert the phrase "six copies" in lieu thereof.

2.05 Before Starting Construction: C. - delete the paragraph in its entirety and substitute the following:

"C. Evidence of Insurance: Before any work at the site is started, CONTRACTOR shall file certificates of Insurance acceptable to the OWNER with the OWNER which the CONTRACTOR is required to purchase and maintain in accordance with Article 5."

3. ARTICLE 3 - CONTRACT DOCUMENTS: INTENT, AMENDING, REUSE

3.01 Intent: - add the following paragraph:

"D. Within the Specifications the order of precedence shall be as follows: Addenda, Supplementary General Conditions, Information for Bidders, General Conditions, Technical Provisions."

4. ARTICLE 4 - AVAILABILITY OF LANDS: SUBSURFACE AND PHYSICAL CONDITIONS; REFERENCE POINTS

4.02 Subsurface and Physical Conditions: A.1 and A.2. - delete these paragraphs in their entirety and substitute the following:

"1. See Section 01030 - Special Project Procedures."

4.05 Reference Points: - add the following paragraph:

"B. Surveys to be furnished to the CONTRACTOR by the OWNER will be as specified in Division 1 GENERAL REQUIREMENTS."

5. ARTICLE 5 - BONDS AND INSURANCE

5.01 Performance, Payment and Other Bonds: - add the following sentence to paragraph "B":

"The CONTRACTOR shall furnish a Statutory Bond which is a surety bond, running to the State, conditioned that the CONTRACTOR, as principal, shall pay all indebtedness incurred for labor, supplies, equipment and materials furnished in making the improvements called for by the contract documents."

5.01 Performance, Payment and Other Bonds: - add the following paragraph:

"D. Upon notice of award and prior to execution of the contract, any successful bidder who is not a legal resident of the county in which the work is located shall appoint his process agent in accordance with Section 16113, General Statutes of Kansas, 1949, as amended. The term of appointment of this process agent shall be for the full term of the surety bonds to be furnished by the CONTRACTOR as a part of these contract documents."

5.04 Contractor's Liability Insurance: - add the following paragraph.

"C. The CONTRACTOR shall not commence work under this contract until the insurance required by OWNER is obtained, approved and filed with the OWNER; nor shall the CONTRACTOR allow any subcontractor to commence work until the insurance required of the subcontractor has been obtained, approved and filed with the OWNER. The certified Insurance Policy to be filed by the CONTRACTOR with the OWNER shall provide the following coverages:

1. Comprehensive General Liability covering premises—operations, xcu hazards when applicable, Products/Completed operations, Broad Form Property Damage and Contractual Liability with minimum limits as follows:

Bodily Injury Liability	\$1,000,000 Each Occurrence
	\$1,000,000 Each Aggregate

Property Damage Liability	\$1,000,000 Each Occurrence
	\$1,000,000 Each Aggregate

Or

Bodily Injury and Property Damage Liability (Combined Single Limit)	\$1,000,000 Each Occurrence
	\$1,000,000 Each Aggregate

2. Automobile Liability-Comprehensive Form including all owned, hired and non-owned vehicles with minimum limits for

Bodily Injury Liability	\$1,000,000 Each Accident
Property Damage Liability	\$1,000,000 Each Accident

Or

Bodily Injury and Property Damage Liability (Combined Single Limit)	\$1,000,000 Each Accident
---	---------------------------

3. Workers' Compensation/Employers Liability for minimum limits of

Employers Liability:

Statutory

In the Insurance Policy, the Insurance Company must state that the Contractual Liability includes the Liability of the OWNER and ENGINEER assumed by CONTRACTOR in the Contract Documents. The Policy must also state that the OWNER will be given written notice if the policy is cancelled or changed within ten (10) days prior to the effective date thereof.

Said Insurance Policy shall be furnished to the OWNER before the agreement is issued."

5.05 Owner's Liability Insurance: A. - delete the paragraph in its entirety and substitute the following:

"A. CONTRACTOR shall include OWNER and ENGINEER as additional insureds under CONTRACTOR'S general liability policy requirements set forth in Article 5.04 of the General Conditions."

5.06 Property Insurance: A. - delete the first sentence and substitute the following in lieu thereof.

"CONTRACTOR shall purchase and maintain property insurance upon the Work at the site to the full insurable value thereof (subject to such deductible amounts as may be provided in the Supplementary Conditions or required by Laws and Regulations)."

5.06 Property Insurance: B. and E. - delete these paragraphs in their entirety. No substitution will be made.

5.07 Waiver of Rights: A. - delete the last sentence of the paragraph in its entirety. No substitutions will be made.

5.08 Receipt and Application of Insurance Proceeds: A. and B. - delete these paragraphs in their entirety. No substitutions will be made.

5.09 Acceptance of Bonds and Insurance; Option to Replace: A. - Delete the first sentence and substitute the following in lieu thereof.

"A. If the OWNER has any objections to the coverage afforded by or other provisions of the Bonds or Insurance required to be purchased and maintained by the CONTRACTOR in accordance with Article 5 on the basis of non-conformance with the Contract Documents, the OWNER shall so notify the Contractor in writing within 10 days after receipt of the certificates (or other evidence required) required by Paragraph 2.05.C."



6. ARTICLE 6 - CONTRACTOR'S RESPONSIBILITIES

6.10 Taxes: - add the following paragraph

"B. For tax exempt status see Section 01060 Regulatory".

6.11 Use of Site and Other Areas: A. Limitation of Use of Site and Other Areas - add the following paragraph:

"4. During the progress of the work the convenience of the local public and of residents along the work shall be considered and, where possible, their rights of access shall be preserved. Temporary driveways, approaches and crossings shall be provided where practicable and maintained in good condition. Construction materials shall be so stored or stockpiled as to cause as little obstruction as possible and still be readily accessible for use or inspection. No material shall be stored within 2 feet of any tree or building nor within 5 feet of any fire hydrant; fire hydrants shall remain ready for immediate use by the fire department. The CONTRACTOR'S proposed schedule for beginning new sections of the work shall be coordinated with and approved by the ENGINEER. To prevent extended inconvenience to the local residents, the CONTRACTOR will not be permitted to open up extensive areas for work during periods when cold or other weather conditions which would curtail the work are normally expected."

Shop Drawings and Samples: 6.17A and B - The number of copies of shop drawings and samples to be submitted will be six.

7. ARTICLE 7 - OTHER WORK - No changes, additions or amendments.

8. ARTICLE 8 - OWNER'S RESPONSIBILITIES - delete paragraph 8.06.A in its entirety, no substitution will be made.

9. ARTICLE 9 - ENGINEER'S STATUS DURING CONSTRUCTION

9.03 Project Representation: - add the following paragraph:

"B. Article 18 - "A LISTING OF THE DUTIES, RESPONSIBILITIES AND LIMITATIONS OF AUTHORITY OF THE RESIDENT PROJECT REPRESENTATIVE" is attached hereto and is a part of these supplemental conditions."

10. ARTICLE 10 - CHANGES IN THE WORK; CLAIMS - No changes, additions, or amendments.

11. ARTICLE 11 - COST OF THE WORK; CASH ALLOWANCES; UNIT PRICE WORK - No changes, additions, or amendments.

12. ARTICLE 12 - CHANGE OF CONTRACT PRICE; CHANGE OF CONTRACT TIMES

Add the following paragraph to 12.01.

"B.4. CONTRACTOR shall not be entitled to a change in the Contract Price, payment, or other compensation at any time due to damages caused by inaccuracy or admission of information referred to in Article 4 of the General Conditions. A claim for an extension of Contract time may be made as provided in Article 12".

13. ARTICLE 13 - TESTS AND INSPECTIONS; CORRECTION, REMOVAL OR ACCEPTANCE OF DEFECTIVE WORK

13.02 Access To Work: - add the following paragraph.

"B. The ENGINEER and/or OWNER may provide one or more Resident Project Representatives to inspect materials to be used in the work and observe construction methods to determine compliance with the Contract Requirements. The ENGINEER and the Resident Project Representatives shall be provided free access to all parts of the work at the project site and to offsite locations where materials or equipment proposed for use in the work are to be produced or fabricated. Resident Project Representatives shall have the authority to reject defective materials; to delay specific construction operations while the acceptability of materials is being determined, or while equipment or machines are being adjusted or calibrated; and to suspend operations on any part of the work not meeting Contract Requirements. Project Representatives shall have no authority to deviate from or waive the requirements of the specifications without written permission of the ENGINEER. Resident Project Representatives will not perform as Superintendent or Foreman for the CONTRACTOR and neither the presence or absence of the Project Representative on the work shall relieve the CONTRACTOR of his responsibility to perform all work in accordance with the Contract Requirements."

13.03 Tests and Inspections: - Add the following paragraph:

"B. So long as the CONTRACTOR'S work progresses in an orderly and reasonable manner the costs of field sample preparation and testing of all specimens will be borne by the OWNER. Should the CONTRACTOR use methods or procedures that require unreasonable or excessive field testing to determine whether specification requirements are being met, or if field testing is performed with continued negative results that indicate the CONTRACTOR'S methods or procedures are not adequate to provide the specified results, the ENGINEER will notify the CONTRACTOR in writing that the costs of all additional testing beyond specific limits, which shall be set out in the written notice for the particular area or material in question, shall be the responsibility of the CONTRACTOR. Such costs will then be deducted from the monies due the CONTRACTOR for the work performed."

14. ARTICLE 14 - PAYMENTS TO CONTRACTOR AND COMPLETION

14.02 Progress Payments: A. Applications for Payment - add the following paragraph:

"4. The Contractor shall submit three (3) copies of each Application for Payment to the Engineer for review."

15. ARTICLE 15 - SUSPENSION OF WORK AND TERMINATION - No changes, additions or amendments.

16. ARTICLE 16 - DISPUTE RESOLUTION - No changes, additions and amendments.

17. ARTICLE 17 - MISCELLANEOUS - Add the following paragraphs:

Nondiscrimination of Employment:

17.06 Contracts for work under this proposal will obligate the contractors and subcontractors not to discriminate in employment practices.

Bidders must submit with their initial bid a signed statement as to whether they have previously performed work subject to the President's Executive Order No. 11246 of September 24, 1965, as amended.

Bidders must, if requested, submit a compliance report concerning their employment practices and policies in order to maintain their eligibility to receive the award of the contract.

Successful bidders must, if requested, submit a list of all subcontractors who will perform work on the project and written signed statement from authorized agents of the labor pools with which they will or may deal for employees on the work together with supporting information to the effect that said labor pools' practices and policies are in conformity with Executive Order No. 11246 of September 24, 1965, as amended, and that said labor pools will affirmatively cooperate in or offer no hindrance to the recruitment, employment and equal treatment of employees seeking employment and performing work under the contract or a certification as to what efforts have been made to secure such statements when such agents or labor pools have failed or refused to furnish same prior to the award of the contract.

Successful Bidders must be prepared to comply in all respects with the Contract Provisions regarding nondiscrimination as contained in the Labor Standards Contract Provisions, May, 1973, a copy is included at the back of this section and indicated as Attachment "C" and Attachment "E".

17.07 By the submission of its bid, each bidder acknowledges that he understands and agrees to be bound by the equal opportunity requirements of EPA regulations (40 CFR Part 8, particularly Section 8.4(b)) which shall be applicable throughout the performance

of work under any contract awarded pursuant to this solicitation. Each bidder agrees that if awarded a contract, it will similarly bind contractually each subcontractor. In implementation of the foregoing policies, each bidder further understands and agrees that if awarded a contract, it must engage in affirmative action directed at promoting and ensuring equal employment opportunity in the workforce used under the contract (and that it must require contractually the same effort of all subcontractors whose subcontracts exceed \$10,000). The bidder understands and agrees that "affirmative action" as used herein shall constitute a good faith effort to achieve and maintain that amount of minority employment in the onsite workforce used in the project which corresponds, for each trade used, to the minority population in the serving labor market area from which workers are reasonably available for hire for the project.

#### EPA Construction Grants Contract Requirements:

17.08 This project is expected to be funded in part by a grant from the United States Environmental Protection Agency and as such will be governed by the Environmental Protection Agency Construction Grants Contract Requirements (Sections 35.936, 35.938, and 35.939 of 40 CFR Part 35, published September 27, 1978 are considered a part of these specifications) which are included at the back of this section and indicated as Attachment "A".

#### Access To Project:

17.09 The Regional Administrator of the U.S. Environmental Protection Agency or his authorized representative, the Chief of Water Pollution Control of the Kansas Department of Health and Environment or his representative shall have access to the work wherever it is in preparation or progress. The Contractor shall provide the proper facilities during inspections.

#### Prevailing Wage Rates And Labor Standards:

17.10 This contract shall be based upon payment by the Contractor and his subcontractors of wage rates not less than the prevailing hourly wage rate for each craft or classification of workmen engaged on the work. Prevailing wage rates shall be as determined by the United States Secretary of Labor.

The Contractor and his subcontractors shall comply with the regulations as set forth in the Labor Standards and the following wage rate decision.

The regulations do not prohibit payment of more than the prevailing rate of wages.

#### Historical And Archeological:

17.11 If during the course of construction evidence of deposits of historical or archeological interest is found, the contractor shall cease operations affecting the find and shall notify the Owner who shall notify the Regional Office of EPA, and Executive Director, Kansas State Historical Society, 6425 SW 6<sup>th</sup> Street, Topeka, Kansas 66615. No further disturbance of the deposits shall ensue until the Contractor has been notified by

the Owner that he may proceed. The Owner will issue a notice to proceed only after the state official has surveyed the find and made a determination to EPA and the Owner. Compensation to the Contractor, if any, for lost time or changes in construction to avoid the find, shall be determined in accordance with changed conditions or change order provisions of the specifications.

#### Contractor's Payment Schedule:

17.12 The Contractors and Subcontractors must provide in writing, within 30 days after initiation of construction, a monthly schedule of estimated payments; these schedules shall be updated any time there is a variation of more than 10 percent in contract price.

#### Buy American:

17.13 The Contractor and his subcontractors, materialmen, and suppliers are required to give preference to domestic construction material and equipment for this project in accordance with the Buy American provisions in Public Law 95217 (Section 215 of Public Law 92500 as amended) and implementing EPA regulations and guidelines.

#### 18. ARTICLE 18 - DUTIES, RESPONSIBILITIES AND LIMITATIONS OF AUTHORITY OF THE RESIDENT PROJECT REPRESENTATIVE

18.01 General: RPR is ENGINEER's agent at the site, will act as directed by and under the supervision of ENGINEER, and will confer with ENGINEER regarding RPR's actions. RPR's dealings in matters pertaining to the on-site work shall in general be with ENGINEER and CONTRACTOR keeping OWNER advised as necessary. RPR's dealings with subcontractors shall only be through or with the full knowledge and approval of CONTRACTOR, RPR shall generally communicate with OWNER with the knowledge of and under the direction of ENGINEER.

#### 18.02 Duties and Responsibilities of RPR

- A. *Schedules:* Review the progress schedule, schedule of Shop Drawing submittals and schedule of values prepared by CONTRACTOR and consultant with ENGINEER concerning acceptability.
- B. *Conferences and Meetings:* Attend meetings with CONTRACTOR, such as preconstruction conferences, progress meetings, job conferences and other project-related meetings, and prepare and circulate copies of minutes thereof.
- C. *Liaison:*
  1. Serve as ENGINEER'S liaison with CONTRACTOR, working principally through CONTRACTOR's superintendent and assist in understanding the intent of the Contract Documents; and assist ENGINEER in serving as OWNER's liaison with CONTRACTOR when CONTRACTOR's operations affect OWNER's on-site operations.

2. Assist in obtaining from OWNER additional details or information, when required for proper execution of the Work.
3. Refer all contacts or inquiries by the general public (any person who does not represent an agency which has jurisdiction over the project) to the Engineer.

D. *Shop Drawings and Samples:*

1. Record date of receipt of shop Drawings and samples.
2. Receive samples which are furnished at the site by CONTRACTOR, and notify ENGINEER of availability of samples for examination.
3. Advise ENGINEER and CONTRACTOR of the commencement of any Work requiring a shop Drawing or sample if the submittal has not been approved by ENGINEER.

E. *Review of Work, Rejection of Defective Work, Inspections and Tests:*

1. Conduct on-site observations of the Work in progress to assist ENGINEER in determining if the Work is in general proceeding in accordance with the Contract Documents.
2. Report to ENGINEER whenever RPR believes that any Work is unsatisfactory, faulty or defective or does not conform to the Contract Documents, or has been damaged, or does not meet the requirements of any inspection, test or approval required to be made; and advise ENGINEER of work that RPR believes should be corrected or rejected or should be uncovered for observation, or requires special testing, inspection or approval.
3. Verify that tests, equipment and systems startups and operating and maintenance training are conducted in the presence of appropriate personnel, and that CONTRACTOR maintains adequate records thereof; and observe, record and report to ENGINEER appropriate details relative to the test procedures and startups.
4. Accompany visiting inspectors representing public or other agencies having jurisdiction over the Project, record the results of these inspections and report to ENGINEER.

F. *Interpretation of Contract Documents:* Report to ENGINEER when clarifications and interpretations of the Contract Documents are needed and transmit to CONTRACTOR clarifications and interpretations as issued by ENGINEER.

- G. *Modifications:* Consider and evaluate CONTRACTOR's suggestions for modifications in Drawings or Specifications and report with RPR's recommendations to ENGINEER. Transmit to CONTRACTOR decisions as issued by ENGINEER.
- H. *Records:*
1. Maintain at the job site orderly files for correspondence, reports of job conferences, Shop Drawings and samples, reproduction of original Contract Documents including all Work Directive Changes, Addenda, Change Orders, Field Orders, additional Drawings issued subsequent to the execution of the Contract, ENGINEER's clarifications and interpretations of the Contract Documents, progress reports, and other Project related documents.
  2. Keep a diary or log book, recording CONTRACTOR hours on the job site, weather conditions, data relative to questions of Work Directive Changes, Change Orders or changed conditions, list of job site visitors, daily activities, decisions, observations in general, and specific observations in more detail as in the case of observing test procedures; and send copies to ENGINEER.
  3. Record names, addresses and telephone numbers of all CONTRACTORS, subcontractors and major suppliers of materials and equipment.
- I. *Reports:*
1. Furnish ENGINEER periodic reports as required of progress of the Work and of CONTRACTOR's compliance with the progress schedule and schedule of Shop Drawing and sample submittals.
  2. Consult with ENGINEER in advance of scheduled major tests, inspections or start of important phases of Work.
  3. Draft proposed Change Orders and Work Directive Changes, obtaining backup material from CONTRACTOR and recommend to ENGINEER Change Orders, Work Directive Changes, and Field Orders.
  4. Report immediately to ENGINEER and OWNER upon the occurrence of any accident.
- J. *Payment Requests:* Review applications for payment with CONTRACTOR for compliance with the established procedure for their submission and forward with recommendations to ENGINEER, noting particularly the relationship of the payment requested to the schedule of values. Work completed and materials and equipment delivered at the site but not incorporated in the Work.

K. *Certificates, Maintenance and Operation Manuals:* During the course of the Work, verify that certificates, maintenance and operation manuals and other data required to be assembled and furnished by CONTRACTOR are applicable to the items actually installed and in accordance with the Contract Documents, and have this material delivered to ENGINEER for review and forwarded to OWNER prior to final payment for the Work.

L. *Completion:*

1. Before ENGINEER issues a Certificate of Substantial Completion, submit to CONTRACTOR a list of observed items requiring completion or correction.
2. Conduct final inspection in the company of ENGINEER, OWNER and CONTRACTOR and prepare a final list of items to be completed or corrected.
3. Observe that all items on final list have been completed or corrected and make recommendations to ENGINEER concerning acceptance.

#### 18.03 Limitations of Authority

A. Resident Project Representative:

1. Shall not authorize any deviation from the contract Documents or substitution of materials or equipment, unless authorized by ENGINEER.
2. Shall not exceed limitations of ENGINEER's authority as set forth in the Contract Documents.
3. Shall not undertake any of the responsibilities of CONTRACTOR, subcontractors or CONTRACTOR's superintendent.
4. Shall not advise on, issue directions regarding or assume control over any aspect of the means, methods, techniques, sequences or procedures of construction unless such advice or directions are specifically required by the Contract Documents.
5. Shall not accept Shop Drawings or sample submittals from anyone other than CONTRACTOR.
7. Shall not authorize OWNER to occupy the Project in whole or in part.
8. Shall not participate in specialized field or laboratory tests or inspections conducted by others except as specifically authorized by ENGINEER.



## SECTION 01030 - SPECIAL PROJECT PROCEDURES

### 1. GUARANTY

The Contractor shall guaranty all materials and equipment as specified in Article 13 of the General Conditions Page 00700-19. It shall be the Contractor's responsibility to notify all suppliers of materials and equipment that the guaranty shall extend one year from the date of substantial completion or as specified otherwise.

### 2. NOTIFICATION

It shall be the Contractor's Responsibility to notify the Owner a minimum of two weeks prior to all construction which requires interfacing with the existing water, sewer, or electrical systems.

### 3. DISPOSAL OF WASTE MATERIALS

The Contractor shall have full responsibility for proper disposal of waste materials. They shall be disposed of at the County Landfill or as otherwise approved in writing by the Engineer.

### 4. TRAFFIC CONTROL

The Contractor shall protect traffic by the use of proper and necessary flags, lights, signals, barricades or other warning devices as needed, all in accordance with the latest edition of the *Manual On Uniform Traffic Control Devices (MUTCD)*, U.S. Department of Transportation, Federal Highway Administration.

### 5. UTILITIES

The Contractor will be required to obtain and pay for all utilities used for the project.

## SECTION 01040 - COORDINATION

### 1. COOPERATION

The Contractor shall cooperate with the Engineer, the Owner and other contractors in performing the work involved in the entire project. Fairness shall prevail as regards to use of access roads, storage space, space for temporary office, utility services, and other facilities. In any arrangement as to the proportion of facilities between contractors, the decision of the Resident Engineer shall be final.

## SECTION 01050 - FIELD ENGINEERING

### 1. SURVEYS

The surveys available to the Contractor have been performed by others for this project.

The Contractor shall re-establish all P.I.'s and Bench Marks. Prior to using any Bench Mark the Contractor shall verify its accuracy.

All other surveys necessary to prosecute the work shall be done by the Contractor with his own surveyors, materials and equipment at his own expense. This will include, but not be limited to, all baseline offset stakes, intermediate elevation hubs, facility or structure offset hubs, batter boards, stringlines, and As-Built dimensions, locations and elevations. No work that requires such surveys are complete and a copy of the field notes are delivered to the Inspector.

No special payment will be made to the contractor for survey work and such work will be considered subsidiary to other related items of work.

## SECTION 01060 - REGULATORY

### 1. PERMITS

All necessary State, City, County, Local and Federal Permits required for construction shall be furnished by the Contractor with the exception of the Kansas Division of Water Resources permits for construction within a stream channel.

### 2. CODES

Execute work in compliance with all applicable Federal, State and Municipal laws, codes, ordinances, and local customs regarding the trade to perform the work.

Codes shall govern in case of any direct conflict between codes and plans and specifications; except when plans and specifications require higher standards than those required by code.

### 3. TAXES

Materials and equipment incorporated for the Street/Drainage and Sanitary Sewer are exempt from the payment of sales tax under the laws of the State of Kansas and shall not be included in the bid of the bidders.

Owner will provide the Contractor with a proper exemption certificate within 10 days of the date of the Agreement. Should the Owner fail to provide an exemption certificate number within the required time period, the Contractor will be reimbursed monthly for sales tax amounts for which he becomes liable until such certificate number is provided.

Upon issuance of a proper exemption certificate number to CONTRACTOR, CONTRACTOR shall assume full responsibility for his own proper use of the certificate number, and shall pay all costs of any legally assessed penalties relating to CONTRACTOR's improper use of the exemption certificate number."

Water line projects are not exempt from the payment of sales tax and shall be included in this bid of the bidders.

## SECTION 01100 - ALTERNATIVES

### 1. SUBSTITUTION OF EQUIPMENT

Whenever a material, article or piece of equipment is identified on the drawings or specifications by reference in brand name or catalog number, it shall be understood that this is referenced for the purpose of defining the performance or other salient requirements and that other products of equal capacities, quality and function shall be considered.

Prior to receiving bids the Contractor may recommend the substitution of a material, article, or piece of equipment of equal substance and function for those referred to in the Contract Documents by reference to brand name or catalog number, and if, in the opinion of the Engineer, such material, article, or piece of equipment is of equal substance and function to that specified, the Engineer may approve its substitution, and an addendum will be issued naming those additional manufacturer's which will be acceptable to the Engineer. The requests for substitutions must be received 10 days prior to bidding.

After execution of the contract, substitution of equipment of makes other than those specifically named in the contract documents will be approved by the Engineers only if the equipment named in the specifications cannot be delivered to the job in time to complete the work in proper sequence to work of other Contractors, due to conditions beyond control of the Contractor.

Requests for substitutions must be accompanied by documentary proof of equality and difference in price and delivery, if any, in form of certified quotations from suppliers of both specified and proposed equipment.

The Owner shall receive all benefits of the difference in cost involved in any substitution, and the contract altered by change order to credit Owner with any savings so obtained.

## SECTION 01150 - MEASUREMENT AND PAYMENT

### 1. GENERAL

The total bid price for each section of the contract shall cover all work shown on the contract drawings and required by the specifications and other contract documents. All costs in connection with the work, including furnishing of all materials, equipment, supplies, and appurtenances; providing all construction plant, equipment, and tools; and performing of all necessary labor to fully complete the work, shall be included in the unit and lump sum prices named in the Proposal. No item that is required by the Contract Documents for the proper and successful completion of the work will be paid for outside of or in addition to the prices submitted in the Proposal. All work not specifically set forth as a pay item in the Proposal shall be considered a subsidiary obligation of the Contractor and all costs in connection therewith shall be included in the prices named in the Proposal.

All incidental, subsidiary and miscellaneous items of work essential to completion of the project in a satisfactory manner shall be done at no additional cost to the Owner. Some, but not all, of the items that shall be considered incidental or subsidiary are as follows:

- a. The support, protection and maintenance of existing utilities such as power and telephone poles, sanitary sewers, manholes, storm drains, and other such items that are to be maintained in place, before, during, and after construction of the proposed improvements.
- b. Traffic control.
- c. Acquisition of additional working space.
- d. Construction Staking.
- e. Other items as noted in these specifications or on the plans.

The method of measurement and basis of payment for each item as listed in the Proposal shall be as stipulated in the following paragraphs. Final Payment to the Contractor will be based on measured quantities, unless otherwise shown.

### 2. PIPE LINES

Pipe Lines shall be paid for on a linear foot basis as measured along the centerline of the pipe, no deductions being made for manholes, valves or fittings. All fittings such as tees, bends, crosses, reducers, couplings, clamps, sleeves, plugs, caps, etc. shown on the plans or required for satisfactory assembly and installation shall be considered subsidiary to the price bid for pipe. Trenching, pipe bedding, backfill, testing, disinfection, etc. shown on the drawings shall be considered subsidiary to the price bid

for pipe. Abandonment of existing waterlines and the filling of existing casing with flowable fill/fill sand shall be considered subsidiary to the price bid for pipe. Pipelines at structures shall be measured to the outside wall line of the structure. Also included in this item is connecting the newly constructed system.

### 3. MANHOLES - Type A, B, and C

Manholes shall be paid for at the contract unit prices bid per each for the various types, based on a 6 vertical feet of manhole, which should include the base section, cone section, adjusting rings and frame and cover. The prices bid shall be full compensation for furnishing all materials, including gasketed frames and covers, pipe used for outside drop manholes, coatings, concrete, grout and for all equipment, tools, labor and incidentals necessary to complete the work. Excavation and compaction of earthwork for this item will not be paid for separately. Extra depth of manhole bid item shall include furnishing and installing the required barrel sections to achieve finished grade.

Vacuum testing is subsidiary to Manholes in Place.

### 4. MANHOLE GRADE ADJUSTMENT

Manhole grade adjustment shall be paid for at the contract unit prices bid per each, which should include the adjusting rings. The prices bid shall be full compensation for furnishing all materials, including gaskets, coatings, concrete, grout and for all equipment, tools, labor and incidentals necessary to complete the work. Excavation and compaction of earthwork for this item will not be paid for separately.

Vacuum testing is subsidiary to Manholes in Place.

### 5. MANHOLE AND SEWER SERVICE CONNECTIONS

This item shall be paid for at the contract unit price bid per each. The price bid shall be full compensation for pipe, fittings, plugs, caps, marking tape, trenching, backfilling, bedding, testing and incidentals necessary to complete the work.

### 6. BORING AND STEEL ENCASEMENT

Boring and Steel Encasement shall be paid for by the linear meter as shown on the plans and shall include the boring and receiving pit, steel encasement, wood skids, sand, concrete and all items described and necessary to complete the boring and encasement per the plans and the specifications.

### 7. STEEL CASING BY OPEN CUT

Steel Encasement shall be paid for by the linear meter as shown on the plans and shall include steel encasement, wood skids, sand, concrete, excavation, trenching, backfill, and all items described and necessary to complete the open cut and encasement per the plans and specifications.

## 8. VALVE ASSEMBLIES

This item shall be paid for at the contract unit price per each for the respective sizes called for in the plans. The unit price bid shall be full compensation for all excavation, valve, valve box, two feet long sections of DI CL SJ pipe, anchor couplings, thrust blocks other materials, tools, equipment, labor and incidentals necessary to complete the work.

## 9. FIRE HYDRANT ASSEMBLIES

Fire Hydrant Assemblies shall be paid for at the contract unit price per each and includes the materials and installation of new fire hydrants, hydrant valve and tee. This price shall be full compensation for trench and backfill, anchor tee, fittings, pipe, gate valve, valve box, concrete pad (as necessary), fire hydrant, thrust blocking and drain rock and incidentals necessary to complete the work.

## 10. TAPPING SLEEVES AND VALVE

Payment for material and installation shall be at the unit price bid per linear foot. Unit price shall be full compensation for all materials and incidentals for a complete installation.

## 11. REMOVE AND REPLACE PAVED AND GRAVEL PAVEMENT

This item shall be paid for at the contract unit price per Linear Foot to the width as required by trenching operations. The unit price bid shall be full compensation for removal and replacement of the pavement and curb and gutter to the limits shown on the plans and includes the furnishing of all materials, equipment, labor, and incidentals necessary to complete the work. The existing material shall be replaced with either concrete, asphalt, or gravel as required and shown on the plans.

12. ASPHALTIC CONCRETE PAVEMENT. These items shall be paid for at the contract unit prices bid per square yard for the thicknesses shown. The limits of the areas to be paid for are as shown on the plans. Other limits will be measured only as directed by the Engineer. Unit price bid shall be full compensation for all bituminous materials, including tack; aggregates; mixing; hauling; spreading; compacting; sampling; sample testing; and for furnishing all other material, equipment, tools, labor and incidentals necessary to complete the individual item of work.

13. 3" BITUMINOUS BASE. This item shall be paid for at the contract unit price bid per square yard. The limits of the areas to be paid for are as shown on the plans. Other limits will be measured only as directed by the Engineer. Unit price bid shall be full compensation for all bituminous materials, including tack; aggregates; mixing; hauling; spreading; compacting; sampling; sample testing; and for furnishing all other material, equipment, tools, labor and incidentals necessary to complete the individual item of work.



14. CRUSHED ROCK BASE. This item shall be paid for at the unit price bid per square yard. The limits of the area to be paid for are as shown on the plans. Other limits will be measured only as directed by the Engineer. The price bid shall be considered full compensation for furnishing all material, including fabric reinforcement; for completing all preparation, hauling, placement, and compaction, and for all labor, equipment, tools, and other incidentals necessary to complete the work.

15. COMBINED CURB AND GUTTER. Concrete Combined Curb and Gutter shall be paid for at the contract unit price bid per lineal foot. Measurement is along the face of curb; including length across entrance drives, storm drain inlets, flumes, and curb depressions; but excluding length across valley gutters. The unit price bid shall be full compensation for all concrete and concrete placement, finishing, jointing, curing, backfilling, and for furnishing all other materials, equipment, tools, labor and incidentals necessary to complete the work.

16. 4" SIDEWALK CONCRETE PAVEMENT. Concrete Driveway Pavement shall be measured and paid for at the contract unit price bid per square foot, in place, at the thickness shown on the plans. The limits of the area to be measured for individual drives shall be the entire surface area from the back of curb to the property line or to the termination of the drive at a point within public right-of-way, as approved by the property owner. The unit price bid shall be considered full compensation for all excavation and compaction, concrete and concrete placement, reinforcement and its placement, finishing, jointing and joint sealing, curing, and for all other material, equipment, tools, labor and incidentals necessary to complete the work.

17. CONCRETE SIDEWALK PAVEMENT REMOVED. This item shall be paid for at the contract unit price bid per square foot for the area shown on the plans, and shall also include saw cuts, disposal of removed material, and backfilling the removal areas with suitable topsoil where necessary. Payment shall be full compensation for removal and disposal of the specified items; and for furnishing all equipment, tools, labor and incidentals necessary to complete the work.

18. STD. WHEELCHAIR RAMP. Wheelchair ramps shall be paid for at the contract unit price bid per each for the locations shown on the plans. Payment shall be full compensation for all costs of excavating; forming; furnishing, placing, finishing, and curing concrete; grooving; furnishing and placing reinforcing steel; aggregates; mixing; hauling; spreading; compacting; sampling; and for furnishing all other materials, equipment, tools, labor, and incidentals necessary to complete the work.

19. CONCRETE DRIVEWAY REMOVED AND REPLACED. This item shall be paid for at the contract unit price bid per square foot for the area shown on the plans, and shall include saw cuts, removal, disposal of removed material; and for all excavation, compaction, concrete and concrete placement, reinforcement and its placement, forming, finishing, jointing, curing, and for furnishing all equipment, tools, labor and incidentals necessary to complete the work.

20. EMBANKMENT. Embankment shall be paid for at the contract unit price bid per cubic yard on the estimated quantity as shown on the bid form. The price bid for "Embankment" shall be full compensation for constructing roadway embankments, including preparation of the areas on which they are to be placed; compaction; unclassified excavation of on-site material; stripping; hauling; and for the furnishing of all labor, tools, equipment and incidentals necessary to complete the work. Materials which are unsuitable for use as embankment shall be wasted at locations to be provided by the Contractor and approved by the Engineer.

22. STORM SEWER STRUCTURES. Storm Sewer Structures shall be paid for at the contract unit price bid per each. The unit price bid shall be full compensation for all excavation, compaction and backfill; concrete and concrete placement; grates and frames; finishing and curing; and for furnishing all other material, equipment, tools, labor, and incidentals necessary to complete the work including connection of curb inlets to the curb and gutter.

23. STORM SEWER AND CULVERT PIPE. Pipe shall be paid for on a linear foot basis as measured from center-of-structure to center-of-structure or to end of full barrel section on end sections, no deductions being made for manholes or inlets. The contract unit price bid shall be full compensation for excavation, placing of pipe and backfill, bedding, compaction, and for all other material, equipment, tools, labor and incidentals necessary to complete the work. End Sections shall be paid for per each at the contract unit price bid for the various sizes shown in the plans.

24. TEMPORARY AND PERMANENT PROJECT SEEDING. These items shall be paid for at the contract contract unit prices bid per acre. The price bid shall be full compensation for furnishing seed, fertilizer, mulch, and water; ground preparation; application of seed, fertilizer and mulch as required by the plans and specifications; watering as required in Section 02487 of these specifications; and for all tools, labor, and incidentals necessary to complete the work.

25. SITE CLEARING AND RESTORATION. Site Clearing and Restoration shall be paid for at the Contract lump sum price bid and shall be full compensation for clearing, grubbing of shrubs, trimming of trees and plant where permitted; removal of trees; removal and replacement of fences, culverts, and signs; removal of debris, placement of safety fencing, and temporary fencing, barricades and flashers, clean-up, and seeding or sodding of all disturbed areas in kind. Removal, repair, and replacement of damaged pavements and travelways for removal and replacement shown in the drawings shall be considered subsidiary to site clearing and restoration. The price bid shall cover all incidental items affected by the work including furnishing all material, equipment, tools, energy and labor necessary to complete the work.

26. EXCAVATABLE FLOWABLE FILL. This shall be paid for at the unit price bid per linear foot of trench filled regardless of trench depth and/or pipe sizes unless indicated otherwise by plans or contract. The unit price bid shall include all materials, excavation, backfilling, equipment, labor, miscellaneous items and incidentals necessary to complete this work.

27. EROSION CONTROL (BMP's). This item shall be paid for at the contract lump sum bid installed at the locations as shown on the plans or detailed. The unit price bid shall include sediment barriers, inlet protection, temporary construction entrances and all other materials, equipment, labor and incidentals necessary to complete the work. Also included in this item is maintenance of the sediment barriers throughout construction and removal of these barriers once a substantial stand of protective cover is established, as approved by the Engineer.

## SECTION 01300 - SUBMITTALS

### 1. CONSTRUCTION SCHEDULE

The Contractor shall submit his proposed progress schedule for the Engineer's approval within 10 days after the effective date of the Notice To Proceed. The Contractor's progress schedule, when approved by the Engineer, shall be used to establish major construction operations and to check on progress of the work. The Contractor shall provide sufficient materials, equipment and labor to assure completion of the work in accordance with the approved schedule.

The Contractor shall review the construction phasing or sequencing requirements noted on the plans when preparing the construction schedule. Any deviation from the phasing or sequencing requirements shall be noted and an alternative submitted in writing to the Engineer for approval.

If the Contractor's progress falls significantly behind the approved schedule, the Contractor shall, upon the Engineer's request, submit a revised schedule for completion of the work within the contract time and modify his operations to provide such additional materials, equipment and labor necessary to meet the revised schedule. Should the prosecution of the work be discontinued for any reason the Contractor shall notify the Engineer at least 24 hours in advance of resuming operations.

### 2. SUBMITTALS

- a. The Contractor shall within 15 days after award of contract start sending submittals for approval. The Contractor shall prepare or have prepared in a neat and workmanlike manner, submittal drawings and shop details for all equipment and materials furnished under this Contract. The submittals shall contain the following:
  - (1) Six sets of identical submittal data separately stapled with Engineer's submittal form as a cover sheet.
  - (2) Where catalog cuts are used mark them to indicate equipment, capacities, controls, fittings, valves, sizes, model numbers, etc.
  - (3) Reference each item to applicable specification paragraph number and plan sheet number. Reference items not appearing in base specification to applicable alternate numbers, change order numbers, letters of authorization, etc.
  - (4) Shop drawings:
    - (a) All shop drawings shall be checked and signed by the contractor prior to submittal to the Engineer.
    - (b) Shop drawings submitted without contractor's signature or approval and verification will not be approved.

## SECTION 01510 - TEMPORARY UTILITIES

### 1. GENERAL

The Contractor shall furnish and pay for all compressed air, electricity, gas, telephone and potable water service required at the project site. Water necessary for earthwork compaction or other construction operations shall be furnished and paid for by the Contractor. The utilities are as scheduled on the drawings.

### 2. TEMPORARY SANITARY FACILITIES

The Contractor shall furnish and pay for temporary toilet facilities for use by his employees. Facilities shall be serviced regularly and maintained so as to not constitute a nuisance or health hazard.

## SECTION 01700 - CONTRACT CLOSEOUT

### 1. CLEANING

The Contractor shall remove all debris and thoroughly clean the project prior to final inspection.

### 2. FINAL INSPECTION

It is the Contractor's responsibility to schedule the final inspection and notify the Engineer and all subcontractors of the date, time, and place thereof. All work items must be completed. Any deficiencies discovered during the final inspection will be noted and the Contractor will be given 15 days to correct those so noted.

## **DIVISION 2 - SITEWORK**

### **SECTION 02001 - GENERAL**

#### **1. SCOPE OF WORK**

The work covered under this Section shall include clearing and grubbing; all excavation required for construction of roads, streets, drives, and parking areas; formation of embankments, fills, and backfills; demolition, dewatering, excavation for culverts, storm drains, sanitary sewers, water lines, manholes, drainage structures, channels, and ditches; subgrade preparation, area and finish grading; hauling, placing, watering and compacting; disposal of surplus and waste materials; utilities; and all miscellaneous and incidental operations necessary to construct and complete the work in compliance with the dimensions, lines and grades as shown on the plans.

#### **2. OBSTRUCTIONS**

The Contractor shall work around all utilities, structures, fences, trees, shrubs, pavement, and other items shown to remain within the work site, easements, and rights-of-way, unless he determines removal, resetting, replacement, or adjustments will be required to accomplish the work. The Contractor shall bear all costs for the removal, resetting, replacement, and/or adjustment or repair of those items affected as directed by the Engineer, at no additional cost to the Owner.

#### **3. CLEANUP**

Upon completion of construction the Contractor shall remove all debris resulting from construction. All soil banks shall be leveled and excess material disposed of as specified in Section 02201-6 for Type B compaction. The entire area involved in this contract shall be left in a clean and sightly condition.

#### **4. DISPOSAL OF WASTE MATERIALS**

Materials obtained from demolition of the existing facilities, sewer lines, manholes, concrete rubble, concrete encasement excavation, existing fence, trees, shall be removed from the project site and disposed of at the County Landfill or as directed by the Engineer. Material containing vegetation stripped from the site shall be stockpiled during construction and spread for topsoiling of grassed areas after the site grading is completed. Excess soil shall be wasted on site or at other approved sites and placed in accordance with Type B compaction requirements.

## SECTION 02100 - SITE PREPARATION

### 1. STRIPPING

The Contractor shall strip all vegetation and other objectionable material from all areas of original ground on which pavement, concrete slabs, fill or footings are to be placed. Where shown on plans, the strippings shall be deposited at approved locations on the site, but shall not be used for backfilling trenches, or structures. No direct payment will be made for stripping.

### 2. DISPOSAL OF SURPLUS MATERIALS

All material from stripping and all excess excavation or trenching material not required for filling or backfilling shall be wasted at the jobsite, as shown in the plans or as directed by the Engineer.



## SECTION 02200 - EARTHWORK

### 1. GENERAL

1.1 Related Documents: General Conditions and Supplementary Conditions apply to this Section.

1.1.1 Related Work Specified Elsewhere Are Titled:

- (1) "Earthwork - Streets" Section 02201.
- (2) "Excavation, Trenching and Backfilling for Utilities" Section 02206.
- (3) "Manholes and Cleanouts"; Section 02601.
- (4) "Sanitary Sewer Construction": Section 02605.
- (5) "Water Main Construction": Section 02603.
- (6) "Storm Sewerage Systems" Section 02721.

1.2 Description: Upon completion of the backfilling of trenches and placing fill around structures, the entire site of the work included in this Contract shall be graded to form smooth, uniform slopes around structures. All the remaining area included in this Contract shall be graded to the elevations shown on the Plans to provide adequate drainage away from the structures and to present a neat and workmanlike appearance.

1.3 Quality Assurance: Equipment: Type approved prior to use, for capability of equipment to perform work in an acceptable manner. Compact using tamping rollers, pneumatic tired rollers, three-wheeled power rollers or other type equipment.

1.4 Compaction Control: Contractor shall at his expense, make field density tests to assure correct moisture content and compaction.

### 2. MATERIALS

2.1 Satisfactory Materials: All suitable material taken from excavations shall be used in the formation of embankments, subgrade, and backfill to complete the site grading as indicated on the plans or as directed by the Engineer. All unsuitable excavated materials together with all debris, junk, stones, logs, stumps, roots, and other unsuitable materials shall be removed from the site and disposed of by, and at the expense of, the Contractor.

Satisfactory and unsatisfactory materials will be determined by the Engineer.

2.2 Topsoil: If quantity of topsoil is not available on site and additional topsoil is required, provide approved crumbly surface soil having characteristics of soils in vicinity that produce heavy growth of vegetation.

### 3. EXECUTION

3.1 Conservation Of Topsoil: In cut areas, and in areas under proposed paving, walks, structures and/or buildings, remove topsoil without contamination with subsoil. Spread topsoil in areas prepared for topsoil, or when directed stockpile in locations convenient to areas to receive topsoil later. Strip to depth of 6-inches and keep free of roots, stones or other undesirable materials.

3.2 Excavation: General: Excavate to lines and grades indicated. If unsatisfactory material is encountered, stop work and notify Engineer of condition. Use satisfactory excavated material for fills. Remove unsatisfactory material and surplus excavated material not required for fill and dispose of off site, unless specified otherwise.

3.2.1 Under Proposed Walks: Excavate to subgrade elevations.

3.2.2 For excavation under proposed buildings, paving, utilities, sewers and subdrains see the section noted in Paragraph 1.1.

3.2.3 Classification of Excavation: Unclassified regardless of nature of material encountered.

3.2.4 Protection or Removal of Utility Lines: Protect from damage existing utility lines, etc., shown on the drawings or in locations made known to Contractor prior to excavation and to be retained, as well as utility lines constructed during excavation operations; if damaged, repair at Contractor's expense. Existing utility lines not shown on drawings and existing utility lines in locations not known by Contractor, if damaged, shall be repaired and restored to service at Contractor's expense. When utility lines to be removed are encountered, notify Engineer in ample time for necessary measures to be taken to prevent interruption of service.

3.3 Preparation Of Ground Surfaces For Fill: Strip or remove unsatisfactory material within area upon which fill will be placed. Scarify to depth of 9" and compact to required density at a moisture content of at least optimum.

3.4 Fills and Embankments: Construct at locations and to lines and grades indicated; conform to shape of typical section indicated. Provide and haul in approved material for fill, if material is not available from excavated areas. Fill material shall be satisfactory materials, reasonably free of roots, and other organic material and trash, and from stones greater than 6 inches maximum diameter. Frozen materials are not acceptable for fill. Stones over 3" maximum diameter not acceptable in upper six inches in fills or embankments. Place material in successive horizontal layers of 6" to 9" in loose depth. Compact each layer to required density.

3.5 Backfill Adjacent To Structures: Place and compact uniformly in manner to prevent wedging action or eccentric loading upon or against structures. During backfilling and in forming embankments, do not use equipment that will overload structure in compacting fills. Additional requirements for backfilling for pavements, buildings, sewers and utilities are specified in related sections.

### 3.6 Compaction Of Earthwork

3.6.1 General: This item shall consist of the compaction of earthwork by rolling or tamping, or any combination of these methods in accordance with the method and/or type and at the location indicated on the plans or ordered by the Engineer.

3.6.2 Standard Density Tests: This test is designed to determine the moisture content at which maximum compaction is obtained, and to determine the density (dry weight per unit volume) which is obtained at the moisture content and the test will be made as described in the latest edition of ASTM D698.

3.6.3 Moisture Content Requirement: When sufficient moisture does not exist in the soil or earth material to provide thorough bonding under rolling, a sufficient amount of water shall be added to the soil before it is rolled or tamped to insure bonding during the compaction process. Moisture control shall be one of the following types. The type of moisture control to be used at a specific location shall be as depicted on the plans.

3.6.3.1 Moisture Range 03 (MR 0-3). The moisture content of the soil shall be uniform and shall not be higher than three (3) percentage points above optimum nor lower than optimum of the soil involved. If the soil is unstable at this moisture range, the moisture shall be lowered to the point it is stable as determined by the Field Engineer.

3.6.3.2 Moisture Range 90 (MR-90). The moisture content of the soil shall be uniform and shall be such that the soil can be compacted to the requirements of the type of compaction designated on the plans or ordered by the Engineer.

If Type B compaction is specified with this moisture control, the moisture content shall be sufficient to produce a uniform mixture of the soil and moisture. It will be determined by visual inspection that satisfactory compaction and moisture content is obtained.

The water may be added to the material as it is placed in the embankment, or to the cut area and borrow pits. When it is added to the embankment it shall be thoroughly and uniformly mixed with the material before compaction. The mixing shall be accomplished by the use of spring tooth harrows, disc harrows, disc plows or other equipment, or by other methods approved by the Engineer. When water is added to cut areas or borrow pits, the surface of the areas shall be plowed or otherwise roughened or shaped to permit more rapid penetration of the water and to prevent undue loss of the water.

3.6.4 Compaction Requirements: Compaction requirements are separated into types, depending upon the nature of the soil to be compacted and the degree of compaction desired. The method of attaining the compaction for each of the several types shall be as herein described.

3.6.4.1 Type AA The Contractor shall carefully level up each successive lift or layer and shall make a sufficient number of trips with the roller over the entire surface to insure that all soils are uniformly compacted to a density equal to or greater than ninety-five (95) percent of the Standard Density for each soil in conformance with the latest edition of ASTM-D-698. Each successive lift shall contain only that amount of soil material which will insure sufficient and uniform compaction, but in no instance shall any lift or layer exceed six (6) inches of compacted depth.

3.6.4.2 Type B The Contractor shall carefully level up each successive lift or layer and shall make a sufficient number of trips with tamping or sheepfoot type rollers over the entire surface to insure that all soils are uniformly compacted. Compaction shall be continued until the roller feet ride the surface of the compacted lift. Compaction will be considered as adequate when additional trips do not result in additional compaction or in bringing the roller feet closer to the surface of the lift. Each successive lift shall contain only that amount of material which will insure efficient and uniform compaction, but in no instance shall any lift or layer exceed six (6) inches of compacted depth.

If, due to the sandy material that may be encountered, or due to the high moisture content that may be encountered with some of the soils, the roller will not "build up" so that the tamping feet will ride the surface, or the roller continues to pick up excessive amounts of soil due to excessive moisture content to the soil, the sheepfoot roller may be discontinued and a pneumatic tired roller used, with the permission of the Engineer. When pneumatic tired rollers, meeting the requirements as set out above or as approved by the Engineer are used, each lift shall be rolled not less than ten (10) trips over its entire surface and not more than fifteen (15) trips will be required.

3.6.5 Tamping Adjacent to Structures: Whenever embankments are placed adjacent to structures or at locations where it is not practical to use a roller, the embankment materials shall be tamped by the use of mechanical rammers or tampers. Each layer shall be compacted to a density equal to or greater than that obtained under the above rolling procedure for the type of compaction designated. Each successive lift shall contain only that amount of material which will insure proper compaction, but in no instance shall any layer be greater than six (6) inches of compacted depth. When the quantity of work is small, a hand tamper may be used with the permission of the Engineer.

#### 4. BORROW

4.1 General: If there is insufficient material from the excavations to build the embankments and fills required, the Contractor shall borrow the additional fill material required.

4.2 Dressing of Borrow Pits: Upon completion of work, borrow pits shall be dressed, graded, and sides trimmed to uniform slopes and left in a condition which will present a neat appearance, minimize soil erosion and standing water, and permit accurate measurement.

#### 5. SETTLEMENT

The Contractor shall be responsible for all settlement of backfill, fills, and embankments which may occur within one year after final completion of the contract under which the work was performed.

The Contractor shall make, or cause to be made, all repairs or replacement made necessary by settlement, within 48 hours after notice from the Engineer or Owner.

#### 6. DRAINAGE

6.1 Drainage in Vicinity of Structures: The Contractor shall control the grading in the vicinity of structures and trenches so that the ground surface is properly pitched to prevent water from running into the excavated areas. Water which has accumulated in the excavation through the failure of the Contractor to take proper precautions to prevent such accumulation, shall be removed by the Contractor at his own expense, and the subgrade shall be restored to its proper bearing capacity.

#### 7. TOPSOILING

7.1 Location: Apply topsoil to areas of project other than areas to receive structures, buildings, walks, gravel strips and pavings. Coordinate with landscape drawings and specifications.

7.2 Preparation: Excavate cut areas 4" below finish elevation and scarify and compact to required density. Leave fill areas down 4" below finish elevations.

7.3 Installation: Place and compact to 90% of Standard Proctor Density to a thickness after compaction of 4". Finish to elevations called for on the drawings and to a smoothness suitable for seeding, sprigging or planting as called for on landscape drawings.

7.4 Protection: Protect newly graded areas from traffic and erosion. Repair areas of settlement or washing away that may occur and re-establish grades to required density, elevations and slopes.

## SECTION 02201 - EARTHWORK - STREETS

### 1. GENERAL

The work covered under this Section shall include clearing and grubbing; all excavation required for construction of roads, streets, drives, and parking areas; formation of embankments, fills, and backfills; excavation for culverts, storm drains, manholes, drainage structures, channels, and ditches; subgrade preparation, area and finish grading; hauling, placing, watering and compacting; disposal of surplus and waste materials; and all miscellaneous and incidental operations necessary to construct and complete the work in compliance with the dimensions, lines, and grades as shown on the plans.

### 2. WATER

Water can be obtained from any source such as wells, streams, ponds, lakes, waterlines, etc., provided that the Contractor shall obtain all permits and withstand all costs for obtaining and transporting the water to the work site.

### 3. CLEARING AND GRUBBING

This item shall consist of clearing and/or grubbing, including the disposal of materials, for all areas within the limits designated on the plans or as required by the Engineer.

Clearing and grubbing shall consist of clearing the surface of the original ground of the designated areas, areas to be excavated, or areas to receive embankment of all trees, stumps, down timber, logs, snags, brush, undergrowth, hedges, grass, weeds, fences, debris, and rubbish of any nature to a minimum depth of two feet below grade or subgrade, and the disposal from the project site of all spoil materials resulting from clearing and grubbing operations.

The manner and location of disposal of materials shall be subject to applicable laws and ordinances and to the approval of the Engineer. When the Contractor is required to locate a disposal area outside the limits of the project site, he shall obtain and file with the Engineer, permission in writing from the property owner for the use of his property for this purpose.

### 4. REMOVAL OF EXISTING STRUCTURES

This item shall consist of the removal and satisfactory disposal of such portions of existing structures as provided in the plans and specifications or ordered by the Engineer.

Where pipe culverts, or other items with a salvage value are removed, reasonable care shall be exercised in their removal.

All such salvageable items shall remain the property of the Owner, and shall be stored on the project site at locations approved by the Engineer.

All material which is not considered of value by the Engineer shall be disposed of under the same provisions as listed for clearing and grubbing.

## 5. EXCAVATION FOR STREETS

This work shall consist of excavating the project proper, removing and satisfactorily disposing of all materials taken from within the limits of the work, also such excavation as is necessary for inlet and outlet ditches, channels, shaping and sloping of embankments, excavation for combined curb and gutter, street, alley, and driveway returns and pavement, strictly to the required alignment, grade and cross sections as shown on the plans.

5.1 Classification of Excavation. All material excavated shall be defined as "Unclassified Excavation".

5.2 Construction Methods. All suitable materials removed from the excavation shall be used, as far as practicable, in the formation of the embankment, subgrade, and at such other places as directed by the Engineer.

During construction, the roadbed shall be maintained in such condition that it will be well drained at all times. Unsuitable roadbed material encountered in cuts shall be excavated to the lateral limits and depth indicated on the plans or specified by the Engineer. The material removed shall be replaced with suitable embankment material, or with special backfill when so indicated on the plans or in the specifications.

5.3 Construction Requirements. The subgrade shall be excavated or filled until it is, after proper compacting, at such an elevation that the pavement or surfacing, when constructed as shown on the plans, will conform to the established grade and cross section.

Included in earth excavation shall be all incidental work such as stripping, plowing, scarifying, refilling, shaping, trimming, watering, compacting, resetting valves, boxes, and all preliminary work required to make the site ready for pavement or surfacing construction.

When the plans do not indicate use of a Subgrade Treatment, the Subgrade for the pavement or surfacing shall be scarified to a depth of eight (8) inches, and worked free of clods by disking and blading to insure a uniform depth of compacted material.

After scarifying, disking, and blading is completed, the entire area shall be compacted as specified hereinafter and a final rolling by means of a pneumatic roller or a smooth steel roller. Pneumatic-tired rollers shall be loaded to provide a gross weight of at least two hundred and twenty-five (225) pounds per inch of width of tire tread. Smooth steel rollers shall weigh not less than two hundred and fifty (250) pounds per inch of roller length. An approved type of subgrade planer shall be used in forming the subbase in lieu of the smooth rolling specified above.

Any irregularities or depressions that develop under rolling shall be corrected by loosening the material at these locations and adding, removing, or replacing material and re-rolling until the proper cross section and density are obtained. Any portion of the area which is not accessible to a roller shall be compacted to the required density by approved mechanical tampers.

In those areas that are to receive pavement or surfacing, the top of the subgrade shall be of such smoothness that, when tested with a 10-foot straightedge applied parallel and at right angles to the centerline, it shall not show any deviation in excess of 3/8 inch or shall not be more than 0.05 foot from true grade as established by grade hubs or pins. The Contractor shall protect the subgrade from damage and keep it effectively drained until surfacing material is placed thereon. In the event of ruts or erosion the subgrade shall be reshaped, refilled, and rerolled as directed by the Engineer.

All surplus excavated material shall be used to uniformly widen embankments, backfill behind curbs, flatten slopes, or shall be deposited in such locations as the Engineer may direct.

## 6. EMBANKMENTS

This item shall consist of the construction of embankments, including preparation of the areas upon which they are to be placed, in accordance with the specifications and to the lines, grades, and sections shown on the plans or as ordered by the Engineer.

6.1 Construction Requirements. Immediately prior to the placing of the fill materials, the entire area upon which the embankment is to be compacted to Type B or better, except where limited by rock, shall be scarified and broken by means of a disc harrow or plow, or other approved equipment, to a depth of 6 inches. Scarifying shall be done approximately parallel to the axis of the fill.

Embankments requiring compaction shall be constructed in accordance with the following item on "Compaction of Earthwork". Material to be wasted shall be placed in uniform, horizontal layers not exceeding twelve inches in thickness over the full width of the embankment. Each layer shall be bladed until it is level and uniform before the succeeding layer is placed.



The quantity and quality of equipment in use on the project and the amount of blading and rolling performed shall be sufficient to process the amount of material being delivered to the embankment area. The Engineer shall have the authority to require the suspension of embankment operations at any time until the previously delivered materials are properly placed.

During construction of the embankment, the Contractor shall route his equipment, both when loaded and when empty, over the layers as they are placed and shall distribute the travel evenly over the entire width of the embankment. Starting layers shall be placed in the deepest portion of the fill. Haul road locations from borrow pits shall be routed as approved by the Engineer.

Frozen material shall not be placed in the embankment nor shall embankment be placed upon frozen material.

No payment will be made separately or directly for haul on any part of the work. All hauling will be considered a necessary and incidental part of the work and its cost shall be considered by the Contractor and included in the contract unit price for the pay items involved.

6.2 Topsoil. When topsoil is specified or required, it shall be salvaged from stripping or other grading operations. If at the time of excavation or stripping the topsoil cannot be placed in its proper and final section of finished construction, the material shall be stockpiled at approved locations. Stockpiles shall not be placed on areas which will subsequently require excavation or embankment.

Upon completion of grading operations, topsoil shall be placed as directed by the Engineer.

No direct payment will be made for topsoiling. The quantity removed and placed or stockpiled shall be paid for at the contract unit price for "Unclassified Excavation". No additional payment shall be made for re-handling of stockpiled topsoil.

## 7. COMPACTION OF EARTHWORK

This item shall consist of the compaction of earthwork by rolling or tamping, or any combination of these methods, in accordance with the plans and specifications or at the direction of the Engineer.

7.1 Construction Requirements. The provisions of "Embankments" shall apply to the construction of embankments that are to be compacted, to subgrade compaction except where subgrade stabilization is specified, and to backfill when specified as compacted backfill.

7.1.1 Tamping or Sheepsfoot Rollers - These rollers shall consist of metal rollers, drums, or shells surmounted by metal studs with tamping feet projecting at least 6-1/2 inches from the drum surface. The weight of tamping rollers shall be such that, when fully loaded, the load on each tamper foot shall be not less than two hundred (200) pounds per square inch of cross-sectional area. The load per tamper foot will be determined by dividing the total weight of the roller (loaded) by the number of tamping feet in one (1) row parallel to the axis of the roller.

Multiple-wheel pneumatic-tired rollers shall be constructed so that they can be loaded to a gross weight of at least two hundred twenty-five (225) pounds per inch of width of tire tread. The internal pressure of the tires shall be at least forty-five (45) pounds per square inch and the tires on the front and rear axles shall be staggered so that they will cover the entire area over which the roller travels.

7.1.2 Formation of Compacted Embankments - Embankments shall be formed of satisfactory materials placed in successive horizontal layers of not more than 8 inches in loose depth for the full width of the cross section and shall be compacted as specified before the next layer is placed.

7.1.3 Moisture Requirements - The material in the layers shall be of the proper moisture content before rolling to obtain the desired compaction. Wetting or drying of the material and manipulation when necessary to secure a uniform moisture content throughout the layer shall be required. The addition of water, when required, shall be as the layer is placed on the embankment or prewatered at the source when permitted by the Engineer. Mixing shall be accomplished by the use of spring tooth harrows, disc harrows, disc plows or other approved equipment.

The moisture content of the soil at the time of compaction shall be uniform and within + 3 percentage points of optimum moisture for the soil involved, except for Type B.

The moisture content of the soil being compacted to Type B specification shall be considered too high to insure compaction when, after repeated rollings with a sheepsfoot roller, the roller continues to pick up excessive amounts of soil and refuses to "build up" so that the tamping feet eventually ride the compacted surface. When other types of rollers are used, the moisture content of the soil shall be considered excessive when "bridging" or "building up" of the soil occurs in front of or behind the rear wheels of such rollers, and/or when earth hauling equipment produces ruts in the rolled surface.

Material containing excess water shall be dried by mechanical means or permitted to dry naturally to a moisture content which will allow satisfactory compaction.

7.1.4 Compaction Requirements - Compaction requirements are separated into types, depending upon the nature of soil to be compacted and the degree of compaction desired. Unless otherwise indicated on the plans or in the specifications, the minimum compaction shall be Type B as listed below.

Types of Compaction:

Type I - Compacted density of the soil shall be equal to or greater than ninety-five (95) percent of Standard Proctor Density at optimum moisture as per ASTM D-698 and the latest revisions thereof.

Type II - Compacted density of the soil shall be equal to or greater than ninety (90) percent of Standard Proctor Density at optimum moisture as per ASTM D-698 and the latest revisions thereof.

Type B - The Contractor shall carefully level up each successive lift or layer and shall make a sufficient number of trips with tamping or sheepsfoot rollers over the entire surface to insure that all soils in the lift are uniformly compacted. Compaction shall continue until the roller feet "ride out" on the surface of the compacted lift. Compaction shall be considered as adequate when additional trips do not result in additional compaction or in bringing the roller feet closer to the surface of the lift. Each successive lift shall contain only that amount of material which will insure the required uniform compaction, but in no instance shall any lift exceed six (6) inches of compacted depth.

If, due to the sandy material that may be encountered, or due to the high moisture content that may be encountered with some soils, the roller will not "ride out" on the surface, or the roller continues to pick up excessive amounts of soil, the Contractor may discontinue the use of the sheepsfoot roller and, after obtaining permission from the Engineer, use a pneumatic tired roller for such portions of the work as necessary. When pneumatic tired rollers meeting the requirements listed above are used, each lift shall be rolled not less than ten trips over its entire surface and not more than fifteen trips will be required.

7.1.5 Tamping - Whenever embankments are placed adjacent to structures or at locations where it is not practical to use a roller and compacted backfill, the embankment and backfill materials shall be tamped by mechanical tampers having a tamping face not exceeding one hundred fifty (150) square inches in area. Each layer shall be compacted to a density equal to or greater than that obtained under the above rolling procedure for the type of compaction designated. Each successive lift shall contain only that amount of material which will insure proper compaction, but in no instance shall any layer be greater than 6 inches compacted depth.

## 8. EXCAVATION AND BACKFILLING FOR STRUCTURES AND PIPE

This item shall consist of all excavation and backfilling for structures including manholes, inlets, storm sewers, and culvert pipe; and shall include all the necessary clearing and grubbing, bailing, drainage, pumping, sheeting, shoring and bracing and construction of cofferdams or cribs, and their subsequent removal. The disposal of all unwanted or excess excavated material is also included under this item of work.

See also Section 02721 - "Storm Sewerage Systems".

8.1 Excavation. All excavation for structures and pipe shall be "Unclassified".

The Contractor shall install shoring required for the safety of personnel and protection of the Engineer during the prescribed excavation and trenching.

Temporary support, adequate protection and maintenance of all underground and surface utility structures, drains, sewers and other obstructions encountered in the progress of the work shall be furnished by the Contractor at his own expense.

Where ground water is encountered in excavating or trenching, the Contractor shall remove or lower the ground water by means of well point systems, sheeting and pumping, or other approved methods which will permit preparation of a satisfactory pipe bed or structural subgrade, free from running water. No additional or separate payment will be made for wet excavating or trenching.

8.1.1 Excavation For Structures. The excavation for structures shall be excavated according to the outlines of the footings as shown on the plans and shall be of sufficient size to permit the placing of the full width and length of the footings including the forms. Rounded or undercut corners and edges of footings will not be permitted.

The excavation shall be carried to the elevation shown on the plans or as established by the Engineer.

Suitable and practically watertight cofferdams shall be used whenever water-bearing strata are encountered above the elevation of the bottom of the excavation. They shall be sufficiently large to give easy access to all parts of the foundation form.

Cofferdams shall be sunk to a depth well below the bottom of the excavation or to an elevation as near the bottom of the excavation as foundation conditions will permit; shall be substantially braced in all directions, and of such construction as will permit them to be pumped free of water. Unless otherwise shown on the plans or agreed upon, cofferdams and all sheeting or bracing shall be removed after the completion of the concrete or masonry.

8.1.2 Excavating and Forming Bed for Pipe. The trench shall be excavated to the depth and grade shown on the plans or established by the Engineer. The trench shall be of sufficient width at the top of the pipe, when placed, to permit thorough tamping of the backfill under the haunches and around the pipe, but in no case shall the trench width be less than one foot greater than the external diameter of the pipe with the sides of the trench as nearly vertical as practicable.

All trenching shall be done with a ladder wheel machine (commonly referred to as a trenching machine) or a backhoe. The use of other type machines for trenching will be permitted only by written permission of the Engineer and then only when unusual trenching conditions are encountered. All excavated material not required for fill or backfill shall be removed and wasted as directed by the Engineer. The excavated material shall be laid compactly along the trench and kept trim so as to be of least inconvenience to the public and adjoining tenants. The Contractor shall not obstruct any drainage courses with excavated material.

In excavating, the bottom of the trench shall be so shaped to a template that at least ten percent (10%) of the overall height of the pipe will be in contact with the bottom of the trench as excavated. Recesses shall be excavated to receive bells, or other parts which extend below the outside perimeter of the pipe.

Where a firm foundation is not encountered at the established grade due to soft, spongy, or other unstable soil, all such unstable material under the pipe and for a width equal to the width of the trench shall be removed and replaced with gravel conforming to ASTM C33 size No. 67, properly compacted and of the thickness as required by the Engineer to provide adequate support for the pipe.

When specific details for pipe bedding are shown on the plans they shall control the construction requirements. Specification provisions not in conflict are considered complimentary and shall be complied with in addition to the details provided.

8.2 Backfilling. Structures, culverts and sewers shall be backfilled in accordance with the following requirements. Only approved materials that will produce a dense, well compacted backfill shall be used for backfilling. Materials such as sod, frozen soil, debris, and soil that contains a large amount of organic matter shall not be used. When

permitted by the Engineer, compacted sand may be used in lieu of earth for compacted backfill except for the top two feet. Water shall be drained from the areas to be backfilled. If, in the opinion of the Engineer, it is not practicable to drain the areas to be backfilled, the backfill areas shall be dewatered by means of bailing or pumping.

No backfilling shall be placed against any structure until permission is given by the Engineer.

The backfill material shall be deposited on both sides of all structures and sewers at approximately the same elevation and the same time. Special care shall be taken to prevent any wedging action against the structure, or lateral displacement of the pipe.

The material shall be placed in layers and compacted by means of mechanical tampers or hand tampers. Each layer shall be compacted to a minimum density equal to or greater than that of the surrounding undisturbed soil and the top two feet shall be compacted to meet the requirements of Type II Compaction. Each successive layer shall contain only the amount of material that is required for proper compaction, but in no case shall any layer be greater than four (4) inches compacted depth. The moisture content of the soil shall be sufficiently near optimum to insure the required density.

The compaction of the earthwork around any structure shall be carried to the grade as shown on the plans or set by the Engineer. Catch basins, manholes, inlets, sewers, and miscellaneous structures shall be backfilled in accordance with the methods outlined above, except that compaction of the backfill will not be required where structures are outside the roadway right-of-way or any other traveled way. Sewers outside the roadway shall be compacted to the springline of the pipe and the remaining trench backfilled as approved by the Engineer.

When specific details for backfilling in trenches for pipe or culverts, or around structures are shown on the plans they shall control the construction requirements. Specification Provisions not in conflict are considered complimentary and shall be complied with in addition to details provided.

8.3 Settlement. The Contractor shall be responsible for all settlement of backfill, fills, and embankments which may occur within one year after final completion of the contract under which the work was performed.

The Contractor shall make, or cause to be made, all repairs or replacement made necessary by settlement, within 48 hours after notice from the Engineer.

## SECTION 02206 - EXCAVATION, TRENCHING, AND BACKFILLING FOR UTILITIES

### 1. GENERAL

1.1 Related Documents: General Conditions and Supplementary Conditions apply to this Section.

#### 1.1.1 Related Work Specified Elsewhere Are Titled:

- (1) "Earthwork": Section 02200.
- (2) "Manholes and Cleanouts": Section 02601.
- (3) "Sanitary Sewer Construction": Section 02605.
- (4) "Water Main Construction": Section 02603.
- (5) "Storm Sewerage Systems": Section 02721.

1.2 Description: This Section includes Trenching and Backfilling for Site Utilities from 5 feet outside building lines to the connection with City utilities and/or for City utilities within City or Public Easements. Also included in this Section is the excavation and backfilling for incidental utility structures.

1.3 Quality Assurance: Equipment: Type approved prior to use, for capability of equipment to perform work in an acceptable manner. Compact using vibrating plates, tamping rollers, pneumatic tired rollers, three-wheeled power rollers or other type equipment.

1.4 Compaction Control: Contractor shall at his expense, make field density tests to assure correct moisture content and compaction.

### 2. MATERIALS

#### 2.1 Satisfactory Materials:

##### 2.1.1 Pipe Bedding Material:

2.1.1.1 Granular Bedding Material shall be an approved material consisting of a durable crushed rock conforming with the requirements of the latest revision of ASTM C-33 Size No. 67 (3/4" to No. 4); to be placed in not more than 6" layers and compacted by slicing with a shovel or vibrating. Soundness, abrasion, and absorption limits shall be as required for coarse aggregates in Section 03010-Concrete Work.

2.1.1.2 Sand-Gravel Bedding Material - sand-gravel mix meeting Type UD-1 of the 1990 Kansas Standard Specifications for State Road and Bridge Construction.

2.1.1.3 Compacted Embedment shall be an approved sand material free from debris, organic material, and stones with 100% passing thru 3/4" sieve to be placed in uniform layers not more than 6" thick and compacted to 95 percent maximum density as determined by ASTM D698. Granular Bedding Material may be substituted for all or part of Compact Embedment Materials.

2.1.2 Trench Zone Material:

2.1.2.1 Compacted Granular Backfill material shall be an approved sand material free from debris, organic material and stones with 100% passing the 3/4" sieve and not more than 15% passing a No. 200 sieve; to be jetted and mechanically vibrated into place and compacted to 95% density as determined by ASTM D698.

2.1.2.2 Uncompacted Earth Backfill material may be natural soil free from large clods or stones, brush, roots more than 2 inches in diameter, debris, and junk. Flooding with water shall be provided as directed by the Engineer.

2.1.2.3 Compacted Earth Backfill shall consist of material existing prior to trenching or selected material as directed by the Engineer, and shall be compacted to 90% density as determined by ASTM D698. For backfilling at grade beneath existing streets or proposed streets see paragraph 3.3.5. For backfilling at grade under graveled streets see Paragraph 3.3.6.

2.2 Satisfactory and unsatisfactory bedding and trench backfilling materials will be determined by the (soils) engineer.

2.3 Topsoil: If quantity of topsoil is not available on site and additional topsoil is called for, provide approved crumbly surface soil having characteristics of soils in vicinity that produce heavy growth of vegetation.

3. EXECUTION

3.1 Structure Excavation And Backfilling: General: The Contractor shall perform all excavation to the dimensions and elevations indicated on the drawings for all structures and all incidental work thereto. After the completion of excavation, and prior to commencement of foundation footings, floor or slab construction, the excavation will be inspected and approved by the Engineer to insure that suitable subgrade has been reached. Care shall be taken not to excavate below the depths indicated on the drawings. Where the excavation is made below the elevation indicated on the drawings through the fault of the Contractor, the excavation shall be restored to the proper elevation in accordance with the procedure described below for backfill, or the heights of the walls or footings shall be increased, at the expense of the Contractor. Excavation shall extend a sufficient distance from walls and footings to allow for forms, for installation of services and for inspection, except where concrete for walls and footings is authorized to be deposited directly against excavated surfaces.



3.1.1 Drainage in Vicinity of Structures: The Contractor shall control the grading in the vicinity of structures and trenches so that the ground surface is properly pitched to prevent water from running into the excavated areas. Water which has accumulated in the excavation through the failure of the Contractor to take proper precautions to prevent such accumulation, shall be removed by the Contractor at his own expense, and the subgrade shall be restored to its proper bearing capacity.

3.1.2 Shoring: The Contractor shall do all shoring required for safety of personnel and protection of the Engineer in performing the prescribed excavation and trenching. Shoring and bracing near structures shall remain, when directed by the Engineer.

3.1.3 Pipes Under Concrete Floors: All pipes under concrete floors shall be tested before the trenches are backfilled. After testing the pipe lines, the trenches shall be backfilled with sand and compacted to a density equal to that of the adjacent earth.

3.1.4 Backfill Around Structures: After completion of foundation footings and walls and other construction below the elevation of the final grades, all forms shall be removed and the excavation cleaned of all trash and debris prior to backfilling. Material for backfilling shall consist of that excavated, or approved borrow, and shall be free of trash, lumber, or other debris. Backfill shall be placed in 6 inch layers properly moistened to approximate optimum requirements. Each layer shall be compacted by hand, machine tampers, or other suitable equipment, to a density equal to that of the adjoining earth.

3.1.5 Wet Excavation: Where ground water is encountered in excavating or trenching, the Contractor shall remove or lower the ground water by means of well point systems, sheeting and pumping, or other approved methods which will permit preparation of a satisfactory pipe bed or structural subgrade, free from running water. No additional or separate payment will be made for wet excavating or trenching.

3.2 Trenching, Backfilling And Compacting: Classification of Excavated Materials: No classification of excavated materials will be made. Excavation and trenching work shall include the removal and subsequent handling of all materials excavated or otherwise removed in performance of the contract work, regardless of the type, character, composition, or condition thereof.

3.2.1 Trenching Through Earth: The Contractor shall perform all trench excavation of every description and of whatever substances encountered, to the depth shown on the plans or as directed by the Engineer. All trenching shall be done with a ladder wheel machine (commonly referred to as trenching machines) or a backhoe. The use of other type machines for trenching will be permitted only by written permission of the Engineer and then only when unusual trenching conditions are encountered. All excavated

material not required for fill or backfill shall be removed and wasted as indicated on the plans, or removed and wasted as directed by the Engineer. The excavated material shall be laid compactly along the trench and kept trim so as to be of least inconvenience to the public and adjoining tenants. The Contractor shall not obstruct any drainage courses with excavated material.

Trenches shall be not less than 12 inches nor more than 18 inches wider than the outside diameter of the pipe to be laid therein. Excavation for manholes and other accessories shall have 12 inches minimum and 24 inches maximum clearance on all sides.

The Contractor shall excavate the trench to a minimum of four inches below the pipe barrel for placement of embedment material in the bedding zone in accordance with paragraph Pipe Zone Backfilling. Bell holes shall provide adequate clearance for tools and methods used in installing pipe. No part of any bell or coupling shall be in contact with the trench bottom, trench walls, or granular embedment when the pipe is jointed.

The ground adjacent to all excavation shall be graded to provide drainage away from the work. The Contractor shall remove by pumping or other means approved by the Engineer, any water accumulated in or encountered in the excavation, as specified under Wet Excavation.

The banks of trenches shall be kept as nearly vertical as possible, and shall be properly shored and braced. Shoring and sheet bracing near structures shall remain, as directed by the Engineer. Any deviation from vertical trench walls must be requested in writing from the Engineer.

Temporary support, adequate protection and maintenance of all underground and surface utility structures, drains, sewers and other obstructions encountered in the progress of the work shall be furnished by the Contractor at his own expense.

**3.2.2 Trenching Through Rock:** Whenever rock is encountered in the trench or elsewhere in any excavation required to be made, the rock shall be excavated to a minimum depth of six (6) inches below bottom of the barrel of the pipe for placement of embedment material in the bedding zone in accordance with paragraph Pipe Zone Backfilling. Special care shall be taken to insure that the bells do not rest on rock.

Rock shall not be drilled and blasted with explosives, unless permitted by the Engineer.

**3.2.3 Trenching Through Pavement:** All concrete or bituminous pavement or stabilized base encountered in the line of trenching shall be removed and replaced in a neat line. The pavement replaced shall conform in type and quality to the pavement removed, and shall be one and one third (1-1/3) times the thickness of the original pavement. The existing pavement shall be cut vertically and horizontally to a straight line.

- (3) Class C Bedding shall be used for all rigid pipe.
  - a. Class C Ordinary Bedding shall be used for all rigid pipe unless wet conditions are encountered.
  - b. Class C Improved Bedding shall be used for wet conditions existing in the trench, as directed by the Engineer, at no additional cost to the Engineer. The dimensions shall be equal to that required for "rock" excavation.

3.3.2 Placement and Compaction: After each pipe has been graded, aligned, shoved home and placed in final position on the bedding material, sufficient pipe embedment material shall be deposited and compacted under and around each side of the pipe and back of the bell or end thereof to hold the pipe in proper position and alignment during subsequent pipe jointing and embedment operations.

Embedment material shall be deposited and compacted uniformly and simultaneously on each side of the pipe to prevent lateral displacement.

3.3.3 Backfill: Backfill material and compaction requirements shall conform to either Type I, Type II or Type III as shown on Figure 02206-2. The type of backfill to be used at specific locations shall be as shown on the plans. One year's maintenance will be required on all backfill.

3.3.4 Backfilling Through Rock: Backfilling through rock shall be performed as specified in the paragraph Backfill above, except that the Pipe Zone is increased to provide eighteen (18) inches of cover over the pipe. When approved by the Engineer the remainder of the backfill may be excavated rock provided the excavated rock has been broken up so that earth and rock will thoroughly mix and not result in voids around the larger pieces of rock. Any excess rock remaining after the trench has been backfilled shall be removed or wasted as directed by the Engineer.

3.3.5 Backfilling Under Pavement: Backfilling under pavement shall be performed as Backfill Type I to a level of two (2) feet from the bottom of the pavement. The remainder of the trench shall be backfilled with selected material, sufficiently damp to be properly compacted in layers not exceeding six (6) inches in depth, compaction shall be performed with mechanical tampers and continued until a relative density of 100 percent of standard density, in conformance with ASTM D698, is attained. Type I backfill shall also be utilized on all proposed streets and shall be used to the limits of the R-O-W.

3.3.6 Backfilling Under Gravel Streets: Where the trench crosses or lies in existing gravel surfaced streets, the backfill shall be compacted as provided in the paragraph "Backfilling Under Pavement".

## SECTION 02271 - ROCK RIPRAP

### 1. GENERAL

Rock riprap shall be furnished and installed to the lines, grades, and dimensions as indicated on the plans for the slopes and berms of the embankments.

### 2. MATERIAL

Material is to consist of individual fragments, dense, sound, resistant to abrasion and free of cracks, seam or other defects which would tend to increase unduly their destruction by water and frost actions. Material is to meet the following requirements:

2.1 Minimum weight per cubic foot, not less than one hundred forty (140) pounds when tested in accordance with A.S.T.M. Standard C-127.

2.2 Loss after ten (10) cycles of freezing and thawing to be less than fifteen percent (15%) when tested in accordance with AASHO Designation T-103.

2.3 Broken concrete may be used in lieu of stone, unless otherwise noted on the plans, provided that it is sound and durable and meets the above requirements for size. Trim exposed reinforcement to the surface of broken concrete. Large flat pieces and long sections of curb will not be acceptable.

2.4 The material shall have the following gradation:

TABLE 12b SIZE REQUIREMENTS FOR ROCK RIPRAP

Percent Retained on Sieve Size

D50	12"	10"	9"	8"	6"	5"	4"	3"	2"	1"	1/2"	#4
1"								0	0	35/75	75/90	95/100
2"						0	0/25	10/40	35/65	80/100		
3"					0	0/30	15/50	30/70	50/90	95/100	95/100	
4"				0	0/40	15/150	30/70	45/80	80/100	95/100		
5"		0		15/35		35/65		70/95	85/100			
6"	0		20/40		30/70		65/85	80/100	90/100			

### 3. PLACEMENT

Rock Riprap shall be a carefully placed layer of rock 12 inches thick on a layer of sand and gravel bedding 6 inches thick. Rock riprap may be placed below water providing it is placed by skip or another approved method which will prevent segregation. Stone riprap shall be placed on a prepared 6" subgrade, unless otherwise noted on the plans, so as to produce a reasonably well-graded mass with a minimum practicable percentage of void. Stone riprap shall be placed to its full course thickness in one

operation without displacing the bedding. Placing rock riprap by dumping into chutes or any other method likely to cause segregation will not be permitted. Placement of stone on the slope and in toe trenches shall be accomplished by controlled dumping directly in place. Bulldozing of stone from the upper banks will not be permitted. Use of a drag line or similar equipment operated from the top of the bank to pull stone into position on the upper slope will be permitted. Larger stones should be well distributed and the entire mass of stones in their final position should be stable and free of pockets of small stones and clusters of larger ones; rearrangement of individual pieces by hand may be required to obtain the results described above. A tolerance of plus six (6) inches from the lines and grades shown on the plans will be allowed in the finished rock riprap surface, except that the extreme tolerance should not be continuous over an area greater than 200 square feet.

#### 4. GROUTED ROCK RIPRAP

Grouted rock riprap material shall be the same as rock riprap. This riprap shall be grouted to the limits shown on the plans or as directed by the engineer. Some hand placing of riprap stones shall be necessary to produce reasonably true surfaces and a close fit of stones. The spaces between the stones shall be filled with Type III concrete with sufficient water to form a plastic mix. The grout shall be poured and broomed into the spaces until they are completely filled.

## SECTION 02485 - SEEDING, SPRIGGING AND SODDING

### 1. GENERAL

This work shall consist of the furnishing and planting of seed, sprigs, and/or sod at locations in reasonable conformity with those shown on the Plans or designated by the Engineer and in accordance with these Specifications. The work shall include the preparation of the ground for the planting, fertilizing and mulching, and watering as specified.

### 2. MATERIALS

2.1 Seeds. The Contractor shall provide grass seed of the variety and at the rates as required to produce the live seed rates shown below or as specified on the Plans. The vendor's certified statement for each species of grass and grass mixture stating each variety, percentage by weight, and percentages of purity, germination, and weed seed shall be furnished. Live seed for each grass species is the product of the percentage of purity and the percentage of germination.

The seed shall be new-crop seed complying with and labeled in accordance with U.S. Department of Agriculture "Rules and Regulations under the Federal Seed Act" in effect at date of purchase of seed. All seed shall be furnished in standard containers. Seed which has become moldy, wet, or otherwise damaged in transit or storage shall not be accepted.

A certificate shall be furnished to the Engineer showing the date that the seed was treated. The treated seed shall be planted within twenty-four (24) months after treatment and any treated Buffalo grass seed held by the Contractor or supplied beyond this period shall not be used.

The seed shall be stored in a cool dry place until seeding time. Seed application rate of 8 pounds per 1,000 square feet/K-31 Fescue.

2.2 Sprigs. Sprigs shall be of the grass species specified on the Plans, and shall be healthy, living stems and roots freshly harvested without adhering soil or weeds and obtained from heavy, vigorous growing and mowed turf. After loosening sprigs from the soil, they shall be immediately gathered in piles or windrows and kept moist until planted.

2.3 Sod. Sod shall be of the species and of the size as specified on the Plans. Sod shall be strongly rooted, free of weeds and undesirable grasses, not less than 2 years old, and free of disease. Turf shall be mowed to approximately 2 inches, the sod freshly cut and obtained from areas having similar climatic conditions as the project site. The sod shall have a thickness of 2 to 3 inches, and shall be kept moist until planted.

2.4 Fertilizer. Fertilizer shall be proportioned as specified on the Plans or shown below and shall be of commercial grade, uniform in composition, free-flowing and suitable for application with approved equipment, delivered to the site in bags or other convenient containers, each fully labeled, conforming to the applicable State Fertilizer Laws, and bearing the same trade name or trade mark, analysis and warranty of the producer. Fertilizer shall be applied at the rate of .5 pounds of actual nitrogen, 1.0 pounds of actual phosphorus, and .5 pounds of actual potassium per 1,000 square feet.

#### 2.5 Mulching.

- (1) Hay Mulch - Prairie hay mulch shall normally be used. The hay shall not contain an excessive quantity of noxious weed seeds. The mulch shall be a sharp grade prairie hay, sedan grass hay or broom sedge or any other type of native hay or grass. Straw shall be 8 inches minimum; 50% shall be 10 inches in length or longer.
- (2) Asphalt Mulch - Asphalt mulch shall be of a consistency for application by distributing machines and shall be Emulsified Asphalt type SS-1 of the type and grade as approved by the Engineer.
- (3) Wood Cellulose Fiber Mulch - Wood fiber mulch shall consist of specially prepared wood cellulose fibers having no growth or germination inhibiting factors, dyed green, and as manufactured by Weyerhaeuser Company, or approved equal. The wood cellulose fiber shall have the characteristic of dispersing rapidly in water to form a homogeneous slurry and remaining in such state while being agitated in hydraulic-slurry equipment.

Wood cellulose fiber mulch shall be shipped packaged or otherwise weighed at a maximum air dry moisture content of 14 percent.

2.6 Water. Water shall not contain substances in the amounts considered harmful for the normal growth of vegetation. The Contractor shall supply water and watering equipment as required for the establishment and maintenance of grassed areas.

### 3. SITE PREPARATION

3.1 Project Coordination. After the construction has been completed, (except as provided below), the site has been brought to final grades as shown on the Plans, and other plantings have been accomplished, the Contractor shall prepare the areas to be grassed as specified. When so directed or permitted by the Engineer, portions of the

construction site may be grassed at different periods of time provided that the planting occurs in proper seasons as specified. Any grassed areas damaged by subsequent operations of the Contractor shall be replanted as directed by the Engineer at no additional cost to the Owner.

3.2 Tillage. The areas required to be grassed shall be prepared for planting by cultivation, removal of all objectionable material, and filling of gullies or depressions. The soil preparation shall be accomplished by disking, harrowing and firming. (Plowing will also be required if so indicated on the Plans.) The minimum depth of soil preparation shall be three (3) inches. Existing weed stubble, small weeds and grass that can be disked shall be cut by the disk and partially incorporated into the soil. Several diskings and harrowings over some areas may be required to provide a satisfactory seedbed. Areas too steep or otherwise inaccessible for disking shall be prepared by hand methods. The minimum depth of preparation of the seedbed where hand methods must be employed shall be two (2) inches. Disking, harrowing and raking shall be done longitudinally on slope areas.

The soil preparation on all slope areas shall be performed with disks and harrows unless demonstration shows such methods impracticable and that hand methods must be used.

During the process of soil preparation, extreme care shall be exercised to avoid injury to all trees that have been planted or designated by the Engineer to be saved.

The Engineer may designate local areas of desirable native perennial grasses to be omitted during the soil preparation. Areas of annual grasses such as cheat, crab grass, triple-awn, etc., shall be destroyed by thorough disking prior to seeding.

3.3 Application of Fertilizer. Fertilizer shall be distributed uniformly at rates shown in Section 2.4 and over the area to be planted, and shall be incorporated into the soil to a depth of at least 2 inches by disking, harrowing or other methods approved by the Engineer. Distribution by means of an approved seed drill or hydro seeder equipped to sow seed and distribute fertilizer at the same time will be acceptable unless otherwise noted on the Plans.

Additional soil conditioners shall be mixed into the soil by disking, harrowing, etc., when specified on the Plans, or as directed by the Engineer and furnished by the Owner.

#### 4. SEEDING

4.1 Time of Seeding. The two general seeding seasons shall be (1) Spring Seeding Season, February 15 to April 20, and (2) Fall Seeding Season, August 15 to September 30. The permissible seeding periods for various seeds may be extended a few days in special cases when mulching is specified to follow the drilling of seeds and fertilizer.



The Engineer reserves the right to delay the drilling or seeding of any seeds or to vary the permissible seeding seasons listed above due to weather or soil conditions or for other causes.

**4.2 Seed Application.** Seeds shall be uniformly distributed with acceptable drills, hydraulic-slurry, or other equipment approved by the Engineer. Broadcasting with a standard grass seeder will be required on areas where it is impossible to operate a drill and this method may also be required for certain small seeds.

When a standard drill with fertilizer attachment is used, certain mixed seeds may be placed in the seed box and the fertilizer placed in the fertilizer compartment. Both may be applied during one (1) operation, unless notes on the Plans require separate applications. Fertilizer may be drilled into the soil or applied by hydraulic-slurry. Broadcasting fertilizers is permissible on rough, rocky slopes where drills cannot operate.

All drills shall be fully adjustable so that they will deliver the seeds and fertilizer at the rates specified on the Plans or ordered by the Engineer. Drills that are in poor repair or that do not deliver the seeds and fertilizer uniformly in each drill furrow, shall not be used. Drills shall be adjustable so that the seeds can be planted and covered a maximum depth of 1/2 inch.

Most of the seeds should be drilled about one-half (1/2) inch deep in a well-prepared and firm seedbed. When the fertilizing and seeding operations start on an area, that area shall be completed as soon as possible. No seeding shall be done during windy weather or when the ground is wet or otherwise non-tillable. The grass seed shall then be covered, using a flexible toothed weeder or other suitable equipment. As soon as this covering operation has been completed, the seeded area shall be rolled again with the Culti-packer, the Culti-packer being run over the area only once parallel with the contours of the ground.

Kentucky bluegrass, Bermuda grass and seeds of similar size shall not be mixed with the coarse types of seeds. The finer seeds may be planted with certain drills by removing the seed tubes or they may be broadcast with hand seeders. Broadcast seeding shall be done when the weather is reasonably calm so that the seed will lodge on the prepared seed bed areas.

**4.3 Mulching.**

- (1) Applying Hay Mulch - Hay mulch shall be the required mulching material, unless specified otherwise on the Plans or directed by the Engineer. After seeding operations are complete the mulch shall be spaced uniformly by hand, manure spreader, or other suitable equipment. The mulch shall be anchored to the soil by a V-type

wheel land packer, a disk harrow set to cut slightly, or other suitable equipment which will secure the mulch firmly into the ground 2 inches or more to form a soil-binding mulch and prevent loss or bunching by wind. Spacing between disks shall not exceed 8 inches. Apply hay mulch at the rate of 2 tons per acre or 90 lbs. per 1000 sq. ft.

- (2) Applying Asphalt Mulch - Asphalt mulch shall be used only on very sandy soils and shall not be used unless specified on the Plans or directed by the Engineer. Emulsified asphalt may be diluted with additional water, when permitted by the Engineer, and applied with approved distributing equipment. The asphalt shall be applied to all areas regardless of slope and the rate of application shall provide a bituminous residual of not less than 0.12 gallons per square yard after loss of water.
- (3) Applying Wood Cellulose Fiber Mulch - Wood cellulose fiber mulch may be used in lieu of hay mulch, when the Contractor elects to use a hydro seeder and the method is approved by the Engineer. Wood cellulose fiber mulch shall be applied at the minimum rate of 2000 pounds per acre, unless specified otherwise.

4.4 Watering. The Contractor shall water the seeded areas as required to assure an acceptable stand of grass.

## 5. SPRIGGING AND SODDING.

5.1 Time of Planting. Cool weather grasses such as bluegrass, fescue, etc. and including Buffalo grass shall be planted in either the spring or fall seasons with periods limited to March 1 to June 15 and September 1 to November 30, except that the spring season can be extended to June 30 for Buffalo grass.

Warm weather grass such as Bermuda grass, etc. shall be planted between April 1 and August 15, except that sprigs shall be planted between April 15 and June 15.

5.2 Planting. The areas to be sodded or sprigged shall be watered prior to planting when the ground is excessively dry.

- (1) Sprigging - Grass sprigs of the variety and spaced as shown on the Plans shall be established by setting root divisions in furrows two (2) inches deep, parallel to the contours, and the roots placed so that they lie end to end in the furrow. The roots shall be covered approximately one (1) inch deep, thoroughly watered and firmed. The furrows shall be left partly open to facilitate additional watering and to hold any mulch applied on slope areas.

Firming shall be done with an approved type roller, so that the top of the sprigs will be slightly below the surrounding surface after the firming process is completed.

- (2) Sodding - Grass sod shall be established by means of setting plugs or strips of sod in the soil. The Plans will show the size of plugs and/or the width of strips required and the required spacing of plugs or strips. Excavation shall be made for each plug or strip so that after tamping, the sod will be flush with the final grade. All plugs or strips shall be firmly tamped and thoroughly watered. After placing, all sods shall be firmed by use of an approved roller, a tamper or other approved methods. On steep slopes the sod may be firmed by compacting with hand shovels. The firming process shall remove all air pockets and shall pack the sod roots firmly into the prepared soil.

On steep slopes, staking of plugs or strips may be required as shown on the Plans or as directed by the Engineer. Stakes shall be of lath or similar materials and shall be driven six (6) inches into the ground, leaving approximately one-half (1/2) inch of the top above the sod line.

### 5.3 Watering.

- (1) Sprigged Areas - Sprigged areas shall be kept thoroughly watered for twenty (20) days. Immediately following, the Contractor shall cultivate all areas between the sprigs with hand tools, to kill all weed growth and leave the soil loose and friable. At the time of cultivating, areas that do not have a satisfactory stand of grass shall be replanted as directed by the Engineer.
- (2) Sodded Areas - The Contractor shall water all sods immediately after placing. All sodded areas shall be kept thoroughly watered by the Contractor for twenty (20) days after laying and as often as required thereafter until completion of other items of work in the Contract.

## 6. PROTECTION AND MAINTENANCE.

The grassed area shall be protected against traffic or other use immediately after planting. The Contractor shall be responsible for the proper care of the grassed area until all work on the entire contract has been completed and accepted, or a minimum period of 30 days, whichever is the longest duration. The Contractor will be relieved from watering grassed areas accepted by the Engineer and the Owner.

All planted areas shall be growing when accepted. Areas not showing a stand of grass or evidence of growth shall be replanted in accordance with these specifications. All costs in connection with replanting grassed areas shall be borne by the Contractor until an acceptable stand of grass is obtained, with no additional cost to the Owner.

## SECTION 02603 - WATER MAIN CONSTRUCTION

### 1. GENERAL

Pipe lines, fittings, and valves shall conform to the specifications as set forth in this section. All pipe, valves, fittings and appurtenances shall be new material unless otherwise specified.

Any section of pipe already laid and found to be defective shall be taken up and replaced without additional expense to the Owner.

When it is necessary to take any water mains and/or fire hydrants out of service due to construction of the project, the Contractor shall notify the Water Department concerning initiation of construction. Notification must be made when those same mains and hydrants are returned to service.

The contractor shall determine if any authorization to use water from the public fire hydrants for construction, testing and flushing is needed. If so, the Contractor shall apply for a permit at the appropriate City Office to authorize usage of water for settlement of backfill, flushing and testing from public fire hydrants. There will be no charge for water used for these purposes on this project.

### 2. TRENCHING AND BACKFILLING

The work shall conform to requirements of the Section entitled "Excavation, Trenching and Backfilling for Utilities", except as modified herein. All piping not supported on soil, sand or gravel shall be supported on concrete piers at every joint. Piers shall be twice the diameter of the pipe and shall be extended at least twenty-four (24) inches into undisturbed soil. Ductile Iron pipe shall be used to span excavated areas adjacent to all structures and shall extend at least thirty-six (36) inches onto undisturbed soil, unless shown otherwise on the plans.

### 3. MATERIALS

3.1 Ductile Iron: The pipe shall be slip joint, flange joint or mechanical joint Class 52 ductile iron pipe, centrifugally cast conforming to ANSI Specification A21.51 (AWWA C-151) installed per AWWA C-600. The pipe shall be cement lined and seal coated with an approved bituminous seal coat in accordance with AWWA Specification C-104 (ANSI A21.4). Rubber gasket joints shall be per the latest revision AWWA C-111.

All ductile Iron pipe and fittings shall be encased in 8 mil (min) low density polyethylene tube encasement in accordance with AWWA C-105.

The ductile iron pipe laying condition is for rigid pipe.

Ductile Iron pipe installed within structures shall be provided without exterior bituminous coating and shall be coated with two (2) coats of Tnemec Series 66 High Build epoxy or approved equal at 4 mils dry film thickness per coat.

Ductile Iron pipe to be installed inside structures shall be 125# A.S.A. flanges with full face red rubber gaskets.

- (1) Joints - Unless otherwise specified, underground cast iron pipe may be bell and spigot, compression ring seal or standardized mechanical joint. All exposed pipe shall be flanged unless shown otherwise on the drawings. All flanges shall be American Standard B 16.1, Class 125. Standardized mechanical joints to conform to AWWA Specifications C111 or ASA A21.11.
- (2) Fittings - Fittings shall conform to AWWA Specifications C110. Compact fittings conforming to AWWA C153 may be used.

3.2 Ductile Iron Pipe For Directional Drilling: Ductile Iron Pipe For Directional Drilling shall be restrained joint pipe of the same class and meeting the same standards of the specified ductile iron pipe and shall utilize "Flex-Ring", "Lok-Ring" or "Snap-Lok" restrained joint type or approved equal.

3.3 Polyvinyl Chloride Pipe: PVC Pipe 4" and larger shall conform to AWWA Specification C-900 or AWWA C-909 (molecularly oriented) pressure Class 150 and shall be made from clean, virgin, NSF approved Type 1, Grade 1 PVC conforming to ASTM resin specification D1784-65T. The workmanship, pipe dimensions and tolerances, outside diameters, wall thickness, eccentricity, sustained pressures, burst pressures, flattening, extrusion quality, marking and all other requirements of Commercial Standards CS256 shall be conformed with in all respects. The pipe shall be suitable for use at maximum hydrostatic working pressures for PVC 1120 of 200 PSI unless otherwise shown or specified. The PVC pipe shall be installed per AWWA C-605. The PVC Pipe will be allowed only with prior approval by the City of Newton.

The PVC pipe laying condition is for flexible pipe.

PVC Pipe 2 inches and smaller shall be per ASTM D2241 and NSF Schedule 40 with solvent welds.

- (1) Pipe Joints: Pipe Joints shall provide for contraction and expansions at each joint with a rubber ring, and integral bell as part of each joint. Pipe and fittings must be assembled with a nontoxic lubricant as recommended by the manufacturer. Pipe joint designs shall be submitted to the Engineer for approval.
- (2) Fittings: Fittings shall be C1CL or D1CL conforming to AWWA C110. For 4 inches to 12 inches size pipe, compact fitting conforming to AWWA C153 may be used. Fittings shall have the same coatings as specified for the cast iron pipe. The dry fit of fitting sockets must be snug. If the fit is such that it is loose, the pipe and/or fittings will be rejected as faulty because of improper size. Building up the joint to overcome a loose fit will not be permitted. PVC fittings are not allowed.
- (3) Joint Adapters Joint adapters will be provided for all gate valves, fittings, or changes in pipe material.

- (4) Tapping for Service Installations: When the Contractor is tapping polyvinyl chloride (PVC) water pipe, the tap shall be made using a tapping saddle. The tapping service saddle to be used with PVC pipe shall be Cascade Style CSC1, all stainless steel with a 5-inch shell width and single bolt, or approved equal.
- (5) Marking Service Lines: The Contractor shall provide the plastic flagging material used for marking the ends of the service lines on water line projects. The cost of the plastic flagging material shall be incidental to the service line installations and not be paid for separately.
- (6) Deflection: Deflection of C-900 PVC pipe shall not be permitted except at couplings. Deflection at couplings shall be limited to 4 degrees for 12 inches diameter or smaller. To follow a curve the C-900 PVC pipe may be cut to short lengths and additional couplings may be used. Short lengths shall be no shorter than 6'6" unless approved by the Field Engineer.

3.4 Valves: Valves shall comply respectively with the following sections of these specifications:

- a. Gate Valves - Section 17102
- b. Tapping Sleeves and Tapping Valves – Section 17108

3.5 Valve Boxes: The Valve Boxes shall be of cast iron of the extension type with suitable length for the individual locations unless otherwise specified. They shall have an inside diameter suitable for the particular installation, but in no case shall be less than 4 inches. They shall be painted inside and out with a good quality asphalt paint, and shall be equipped with removable cast iron cover. The Contractor shall furnish to the Owner one valve wrench to operate the valves, which will have valve extensions as detailed in the plans. The wrenches shall be similar to Clow National No. F-2520 or equal.

#### 4.0 CONSTRUCTION METHODS

4.1 General: Each section of pipe bedded in trenches on soil, sand, or gravel, shall rest upon the pipe bed for the full length of its barrel. Recesses shall be excavated to accommodate bells and joints. Any pipe that has its grade or joint disturbed after laying shall be taken up and relaid. The interior of all pipe shall be thoroughly cleaned of all foreign matter before being lowered into the trench, and shall be kept clean during laying operations by means of plugs or other approved methods. Under no circumstances shall pipe be laid in water, and no pipe shall be laid when trench or weather conditions are unsuitable for such work. In all cases water shall be kept out of the trench until the material in the joints has hardened. At all times when work is not in progress, all open ends of pipes and fittings shall be securely closed so that no trench water, earth or other substances will enter the pipe or fittings.

4.2 Pipe Installation: Installation of Ductile Iron Pipe shall be in accordance with AWWA C600 specified herein.

- (1) Handling - Pipe and accessories shall be handled in such a manner as to insure delivery to the work in sound, undamaged condition. Particular care shall be taken not to injure the pipe coating. No other pipe or material of any kind shall be placed inside of any pipe or fitting.
- (2) Cutting - Cutting of pipe shall be done in a neat and workmanlike manner by a method which will not damage the pipe. Unless otherwise authorized, all cutting shall be done by means of mechanical cutters of an approved type. Wheel cutters shall be used whenever practicable.
- (3) Placing and Laying - Before lowering and while suspended, pipe shall be inspected for defects and cracks. Defective, damaged or unsound pipe shall be rejected. Prior to laying, the pipe bedding material shall be placed by slicing with a shovel or mechanical tamping, according to the type of material.
- (4) Joints - Before jointing, all lumps, blisters and excess coating materials shall be removed from the bell and spigot ends of the pipes.

The outside of the spigot and the inside of the bell shall then be wire brushed and/or wiped clean and dry. All oil or grease shall be removed. Flanged joints shall be faced true, and made up perfectly square and tight. Ductile iron wedges shall be used as needed to give proper slope or direction to the line.

- (a) Gaskets - Gaskets for flanged connections shall be 1/16-inch thick neoprene.
  - (b) Slip Joints - Pipe with slip joints shall be lubricated and installed as recommended by the manufacturer of the pipe.
  - (c) The installation of mechanical joints, and bolted joints shall be in accordance with the recommendations of the manufacturer.
- (5) Detection, Protection and Identification - For detection, protection and identification of water mains, the Contractor shall install a detectable metallic marking tape in the trench over the water main at the time of backfilling. The marking tape shall be placed in the trench at a depth of one foot, but not exceeding three feet below the proposed final grade of the ground over the centerline of the water main.



The detectable metallic underground marking tape shall meet the following specifications:

Material	The tape shall be aluminum foil encased in an impervious mylar plastic coating on both sides.
Thickness	The tape shall be 5 mils thick.
Width of Tape	The tape shall be three inches (3") in width.
Printing	The color and printing shall be under the impervious mylar plastic coating. The printing shall be black in color.
Coloring	The color used on the tape shall be blue.
Warning Message	The following warning message shall be repeated on the tape, "CAUTION - BURIED WATER LINE BELOW".

The cost of installing the underground marking tape shall be considered subsidiary to the installation of the water main and not paid for separately.

- (6) Tests - All joints in pressure pipe lines shall remain exposed until the pipe has been hydrostatically tested at the rated pipe pressure at the point of reading. When all joints being subjected to test are found tight at the rated pressure, in the presence of the Engineer, the test may be stopped and backfilling commenced. The cost of testing the pipe lines shall be borne by the Contractor, who shall furnish all equipment necessary for the tests.

#### 4.3 Valves:

- (1) Setting of Valves Underground - All valves shall be installed complete with valve boxes unless otherwise specified. Valves shall be set with stems truly vertical, braced in that position and the joints made as specified for pipe laying. After valves have been installed and adjusted, they shall be watertight and shall operate smoothly. Valve boxes shall be adjusted to proper depth.

#### 5. BORING AND CASING

The Contractor shall bore and encase pipe as shown on the plans or as directed by the Engineer. Borings are to be accomplished with an approved boring rig and with personnel experienced in this type of construction. Boring pits and operations shall be located to avoid conflicts with the public utilities, and other agencies.

As the boring progresses, it shall be concurrently supported with a welded continuous, permanent, new steel pipe casing conforming to ASTM A139 having a minimum diameter as shown on the plans. Steel pipe shall be Grade B under railroads and Grade A on all other uses. Steel pipe shall have a minimum wall thickness as shown in the following table.

<u>Dia. of Casing--inches</u>	<u>Nominal Wall Thickness In Inches</u>	
	<u>Under Railroads</u>	<u>All Other Uses</u>
16	0.281	0.188
18	0.312	0.250
20	0.344	0.250
22	0.375	0.250
24	0.406	0.281
26	0.438	0.281
28	0.469	0.312
30	0.469	0.312
32	0.500	0.312
34	0.531	0.312
36	0.531	0.344
42	0.563	0.375

Borings and encasement shall be constructed so they will drain and shall be bored in a single direction. The pipe shall be pulled or pushed into the casing on lubricated skids as shown in the details and approved by the Engineer. The entire void area between the casing and the sewer pipe shall be filled with blown sand or other approved backfill and the ends of the encasement pipe sealed with concrete plugs.

## 6. TUNNELING

Pipelines shall be constructed in tunnels of the type designated on the Plans. See Section entitled Tunneling.

## 7. REACTION BACKING

Plugs, caps, tees, and bends deflecting 11 1/4 degrees or more on pipes 4 inches in diameter or larger shall be provided with reaction backing which shall be concrete Class II. Backing shall be placed between solid ground and the fitting to be anchored. The area of bearing shall be as shown or as directed. Unless otherwise shown or directed, the backing shall be so placed that the fitting joints will be accessible for repair.

8. WATER MAINS PARALLELING AND CROSSING SEWER LINES. When potable water pipes and sanitary sewers are laid parallel to each other, the horizontal distance between them shall be not less than 10 feet. The laying of water pipes and sanitary sewers shall be in separate trenches with undisturbed earth between them.

When a water pipe and a sanitary sewer cross and the sewer is two feet or more (clear space) below the water pipe, no extra protection to the latter is needed. At all other crossings, the sewer is to be constructed of either ductile iron pipe or approved plastic pipe for a distance of 10 feet in either direction from the crossing. Joints are not to be in the immediate vicinity of the water main and as far from it as practicable.

Where a water line is laid across or through an area where there is an existing sanitary sewer line which is not constructed of DIP, approved plastic pipe, or RCP and the vertical separation is less than 2 ft., the existing sewer line shall be encased in concrete with a minimum 6 inches of concrete for a distance of 10 ft. on each side of the crossing.

A sewer line equal to or less than 20 inches shall also be encased with a minimum of 6 inches of concrete for a distance of 10 ft. on each side of the crossing. Encase the water line where the sewer line is larger than 20 inches.

When crossing water lines over sewer lines is not practical for geotechnical reasons, new sewer lines are to be constructed of DIP, approved plastic pipe, or RCP and extended for a distance of 10 ft on each side of the crossing. Encase new (existing) sewer lines <20 inches in diameter with a minimum of 6 inches of concrete for a distance of 10 ft on each side of the crossing. Encase the water line where the new (existing) sewer line diameter is > 20 inches (Reference: Drawing 7 of 15).

## 9. HYDROSTATIC TESTS

Where any section of a main is provided with concrete reaction backing for fittings or hydrants, the hydrostatic pressure test shall not be made until at least 5 days after installation of the concrete reaction backing, unless otherwise approved.

9.1 Pressure Test: After the pipe is laid, the joints completed, fire hydrants permanently installed, and the trench backfilled, the newly laid piping or any valved section of piping shall, unless otherwise specified, be subjected for 1 hour to a hydrostatic pressure test at the rated working pressure of the pipe. Each valve shall be opened and closed several times during the test. Exposed pipe, joint fittings, valves, and hydrants shall be carefully examined during the open-trench test. Joints showing visible leakage shall be replaced or remade as necessary. Leaking rubber-gasketed joints shall be remade, using new gaskets if necessary. Cracked or defective pipe, mechanical joints, fittings, valves, or hydrants discovered in consequence of this pressure test shall be removed and replaced with sound material, and the test shall be repeated until the test results are satisfactory.

9.2 Leakage Test shall be conducted after the pressure test has been satisfactorily completed. The duration of each leakage test shall be at least 2 hours, and during the test the main shall be subjected to the rated working pressure at the lowest point.

Leakage is defined as the quantity of water to be supplied into the newly laid pipe, or any valved section thereof, necessary to maintain the specified leakage test pressure after the pipe has been filled with water and the air expelled. No piping installation will be accepted until the leakage is less than the number of gallons per hour as determined by the formula:

$$L = 0.0001351 (N) (D) (P)^{\frac{1}{2}} \text{ (PVC Pipe)}$$
$$L = 0.0000075 (S) (D) (P)^{\frac{1}{2}} \text{ (DI Pipe)}$$

in which L equal the allowable leakage in gallons per hour; N is the number of joints in the length of pipeline tested; D is the nominal diameter of the pipe, in inches; S is the length of pipe tested, in feet; and P is the average test pressure during the leakage test, in pounds per square inch gage. The pressure during the pressure or leakage test shall not vary by more than 5 psi from the designated test pressure.

9.3 Retesting: Not less than 30 nor more than 40 days after the pressure test, the Owner may require a measured leakage test of the entire pipeline. Leakage loss shall be within the allowances hereinbefore specified.

## 10. DISINFECTING WATER MAINS

10.1 General: Before acceptance of the new water piping for domestic use by the Owner, the contractor shall flush and disinfect all newly completed piping as prescribed by AWWA Standard C651 and as required in these specifications.

The Contractor shall provide plugs, chemicals, tests, and all materials, equipment, tools, and labor necessary for the satisfactory flushing and disinfection of the new water line as required in these specifications.

10.2 Preventive Measures: The Contractor shall take precautions to protect all interiors, fittings, valves, and assemblies from contamination during work. When pipe laying is not in progress (for example, at the close of a working day), all openings in the installed pipeline shall be plugged watertight and all joints of pipe in the trench shall be completed before work is stopped. If water accumulates in the trench, the plugs shall remain in place until the trench is dry.

The Contractor shall take reasonable measures in scheduling of material and equipment deliveries and in the prosecution of the work to minimize delay in completion of the work and to minimize exposure of the materials to possible contamination.

10.3 Flushing: The new water piping shall be flushed prior to disinfection, except when the Engineer has approved the use of tablets for disinfection. Piping shall be flushed at blow-off assemblies and at fire hydrants at terminal points of the piping.

10.4 Chlorination: After flushing has been completed, the water line shall be disinfected by the "continuous feed" method using an approved liquid chlorine solution.

The disinfecting chemical shall be fed so as to maintain a chlorine concentration of at least 25 mg/l in the water throughout the new piping system.

During disinfection, valves shall be manipulated to prevent backflow of the treated water into the existing water system and also to ensure that all valves and appurtenances are disinfected.

The chlorinated water shall be retained in the pipe line for at least 24 hours. At the end of the 24-hour contact period, the treated water shall contain a free chlorine residual of not less than 10 mg/l.

At the Contractor's request, use of the "tablet method" of disinfection will be given consideration. The Contractor shall submit in writing, for the Engineer's approval before using this method a description of the type and number of tablets and the proposed procedure to be used.

10.5 Final Flushing: After satisfactory disinfection of the water line, the heavily chlorinated water shall be flushed from the piping until the chlorine concentration in the water leaving the main is no higher than that generally prevailing in the water system, or less than 1.0 mg/l. Piping shall be flushed at blow-off assemblies and at fire hydrants at terminal points of the piping.

## DIVISION 3 - CONCRETE

### SECTION 03010 - CONCRETE WORK

#### 1. GENERAL

Concrete shall consist of cement, coarse aggregate, fine aggregate, approved admixtures, and water; proportioned and mixed to produce a workable mixture suitable for specific conditions of placement as noted in the following specifications.

All concrete used in the work shall be air-entrained unless otherwise permitted by these specifications or approved by the Engineer.

All reinforcing steel as detailed on the drawings shall be installed and fastened by ties or supports prior to placing any concrete.

#### 2. MATERIALS

##### 2.1 Portland Cement:

- (1) General - Portland Cement shall conform to the requirements of ASTM Designation C150 and shall be Type II. When approved by the Engineer in writing, Type I or Type III cements may be used in lieu of Type II. Use of special cements containing interground admixtures will not be permitted without approval by the Engineer.
- (2) Packaged Cement - Where packaged cement is to be used in the work, it shall be stored in a suitable moisture-proof enclosure with each shipment properly marked and segregated. Bags of cement in which, for any reason, the cement has become partially set, or which contains lumps of caked cement, shall be rejected.
- (3) Bulk Cement - Bulk cement may be used in the work when approved by the Engineer. Methods of transporting, handling and storage shall also be subject to approval.
- (4) Tests - The Contractor shall furnish certified test reports showing that the cement being supplied complies with these specifications.

2.2 Aggregates: - The use of pit run or naturally mixed aggregates will not be permitted. Fine and coarse aggregates shall be separately furnished and stored.

The mixing of different kinds of aggregates from different sources or alternating batches of different aggregates in one stockpile will not be permitted. In no case shall aggregates containing lumps of frozen or partially cemented materials be used. Aggregates proposed for use in the work shall meet the following requirements.

- (1) Deleterious Substances - Deleterious substances in aggregates shall not exceed the following percentages by weight when tested under the designated ASTM method.

	Coarse	Fine	Test
Material Passing No. 200 Sieve	1.0	3.00	C117
Shale	0.5	0.5	C123
Soft Friable Pieces	0.5	0.5	C142
Sticks (wet)	0.10	0.10	
Coal	0.25	0.25	C123
Clay Lumps (wet, on No. 4 Sieve)	1.5	0.25	C142

No one of the above percentages shall be exceeded when taken separately. In addition, any combination of shale, soft friable pieces, sticks, coal or clay lumps shall not exceed 1.5 percent.

- (2) Coarse Aggregate - Coarse aggregate shall be hard, durable, clean uncoated pieces of crushed rock or gravel. Coarse aggregate will be well graded within the following limits (ASTM Size #67) when tested under ASTM Standard C136.

Sieve Size	1	3/4	3/8	4	8
% Retained	0	0-10	45-80	90-100	95-100

- (3) Fine Aggregate - Fine aggregate shall consist of clean, hard, durable, uncoated siliceous or calcareous particles well graded within the following limits.

Sieve Size	3/8	4	8	16	30	50	100
% Retained	0	0-5	0-20	15-50	40-75	70-90	90-99

The Fineness Modulus (F.M.) of the fine aggregate furnished shall be not less than 2.5 nor more than 3.4 when determined by using a sieve series consisting of the No. 4, 8, 16, 30, 50 and 100 sizes. After acceptance of a gradation for use in the work the F.M. shall not vary more than  $\pm 0.2$ .

- (4) Stockpiles - Aggregates shall be stockpiled by building up free-draining horizontal layers not greater than 4 feet in thickness. Aggregates that have become mixed with earth or foreign material shall not be used. If the water content in coarse aggregate is below that which the aggregate will absorb, such aggregate shall be wet down at least 12 hours in advance of the time the mix is to be batched.
- (5) Aggregate Tests
- (a) General - All aggregates proposed by the Contractor for use in the work shall be certified by an approved Testing Laboratory as complying with the above requirements covering deleterious materials and gradation. In addition, unless waived by the Engineer, certified tests also shall be provided in accordance with Paragraphs (b) thru (e) below. All costs of testing shall be borne by the Contractor.
- (b) Soundness - Coarse aggregate for concrete when tested for soundness with magnesium sulphate in accordance with ASTM Standard C88 shall have a total loss not greater than 18% by weight.
- (c) Abrasion - The percentage of wear of the coarse aggregates by the Los Angeles Abrasion Test, ASTM C131, shall be less than 40%.
- (d) Absorption - Coarse aggregate for concrete shall have an absorption limit of 4% or less, as determined by ASTM C127.
- (e) Mortar Strength - Fine aggregates shall be of such quality that when made into a mortar and tested in accordance with ASTM C87 the mortar shall develop a compressive strengths at 7 and 28 days of not less than 100 percent of that developed by the control mortar specified in C87.

### 2.3 Admixtures:

- (1) General - Admixtures are defined by these specifications as a material, other than portland cement, aggregate or water, added to concrete to modify its properties. The following admixtures shall be used when required and may be used when permitted.



- (2) Air Entraining Agent (AEA) - An approved air entraining agent shall be used to produce 5 to 8% air entrainment in the concrete as placed. The AEA shall be a neutralized solution of vinsol resin meeting the requirements of ASTM C260.
- (3) Calcium Chloride - When approved by the Engineer, calcium chloride meeting the requirements of ASTM D-98 may be used as an accelerator in an amount not exceeding two (2) percent of the weight of cement. No calcium chloride, or admixtures containing calcium chloride, shall be used where aluminum conduit, couplings or accessories are embedded in the concrete.
- (4) Water Reducing Admixtures - At the option of the Contractor, subject to approval of the Engineer, a water reducing admixture (WRA) may be used. Water-reducing, set-controlling admixtures shall be of the basic chemical composition described as "hydroxylated carboxylic acid" or "hydroxylated polymers" and shall meet the requirements of ASTM C494, Type A or Type D. Before approval, the compatibility of the proposed admixture, with the other materials to be used in the concrete mixture, shall be established by test. Where a WRA has been approved for use, and design mix test results demonstrate adequate strength, the Cement Factor may be reduced by 0.5 bag below that specified in Paragraph 3.1, "Proportioning".
- (5) Tests - The Contractor shall furnish three (3) copies of certified test results showing that the admixtures proposed for use comply with these specifications.

2.4 Water: Water used in concrete shall be clean, clear, and free from injurious amounts of sewage, oil, acid, strong alkalis or vegetable matter. If the water is of questionable quality, it shall be tested by a comparative mortar strength test in accordance with ASTM C87.

2.5 Metal Reinforcement: Metal reinforcement shall be Grade 60 billet steel in accordance with ASTM A615. The size, length and shape shall be shown and detailed on the drawings.

2.6 Epoxy-Coated Metal Reinforcement. Where shown on the plans, metal reinforcement shall be epoxy-coated in accordance with the requirements of the latest revision of ASTM D3963.

### 3. PROPORTIONING

3.1 Mix Design: Concrete mixes to be used in the work shall be proportioned in accordance with the requirements of Table 1. All materials shall be proportioned by weight considering one sack of cement as 94 pounds and one gallon of water as 8.33 pounds.

Table 1

Concrete Class*	Minimum 28-Day Strength (PSI)		Minimum Cement Factor	Maximum W/C Ratio	Slump*
	Compressive	Flexural	Bags/C.Y.	Gal./Bag	(in.)
Class I	4000	500	6.5	5.5	1 to 3
Class II	3000	425	5.75	6.0	1 to 3
Class III (sand mix)	3500		8.0	5.75	1 to 3

\*The Class of concrete to be used in the various parts of the work shall be as specified herein or as noted on the drawings. Where no specific class has been designated, Class I concrete shall be used.

\*\*No concrete with slump in excess of 3-inches shall be used in the work without approval of the Engineer.

The Contractor shall design and submit for approval three (3) copies of the proposed design mix for each of the classes of concrete specified for the work. Included with the submittal shall be copies of test reports showing the 7 and 28 day strengths (Flexural and Compressive) for each proposed mix. The proposed design mixes shall be based on the specific materials and the maximum slump to be used in the work. All costs of mix design and testing shall be borne by the Contractor.

3.2 Aggregate Content: The total volume of aggregate used in each cubic yard of concrete shall be the maximum consistent with the requirements of workability.

For Class I and II concretes, the composition of the total aggregate (Fine and Coarse) shall be such that not more than 70% or less than 40% will pass the #4 sieve. The exact proportions of fine and coarse aggregate may be varied within the above limits by the Engineer to produce a concrete mixture more suitable for the work at hand.

For Class III concrete 100% fine aggregate shall be used. Sidewalks and driveways shall be 100% fine aggregate (sand mix) except where an approved mix using coarse aggregate is used due to special construction methods. In such cases, not more than 70% or less than 30% shall pass the #4 sieve.

3.3 Variations in Mix Proportions: The initial concrete mixes used on the work for the various classes of concrete shall be in accordance with the proportions used in the approved design mixes. In the event that these mixes do not produce concretes with the required strength, workability, or air content the Engineer may order changes in the mix proportions to obtain the specified requirements, and the changes so ordered, including additional cement, will be made at no additional cost to the Owner.

3.4 Control: The Contractor shall provide all equipment necessary to determine and positively control the actual amounts of all materials, including admixtures, entering into the concrete. Batching and weighing devices for aggregates and cement shall be accurate within 0.5 percent, and for water and admixtures within 1.0 percent.

#### 4. FORMS

Forms shall be steel or wood as approved by the Engineer and shall conform to the shape, lines, grade and dimensions of the concrete as detailed on the drawings. Lumber used in forms for exposed surfaces shall be dressed to a uniform thickness and free from knots and blemishes. Joints in the forms shall be all horizontal or vertical where the finished surface is to be exposed. Forms shall have nails withdrawn and surfaces to be in contact with concrete thoroughly cleaned and oiled prior to each use. Form oil shall be non-staining and shall be applied to the forms before reinforcement is placed. Forms shall be sufficiently tight to prevent leakage of mortar and properly braced to maintain the desired shape, line and grade.

The removal of forms shall not be started until the concrete has attained the necessary strength to support its own weight and any construction loads. Forms shall not be removed before the expiration of 30 hours from any construction. Forms supported by false work shall not be removed until the concrete has attained its design strength. Where forms are removed less than seven days after placement of the concrete, provisions shall be made to insure curing as specified in this Section under, "Curing of Concrete".

#### 5. REINFORCEMENT

Prior to positioning, reinforcing steel shall be cleaned of all loose mill scale and rust or coatings which might prevent or reduce bond. Reinforcement shall be positioned accurately and secured against any displacement by using annealed iron wire ties or suitable clips and be supported by suitable metal supports, spacers or hangers. All reinforcing shall be in place and securely fastened before placing any concrete. The contractor shall submit shop drawings, bar lists and bending diagrams to the Engineer for approval prior to ordering any reinforcement.

## 6. EPOXY-COATED REINFORCEMENT

6.1 Handling. In order to protect the coated reinforcement from damage, the contractor shall use padded or nonmetallic slings and padded straps. Bundled bars shall be handled in a manner which will prevent excessive sagging of bars which will damage the coating. The bundled bars shall not be dropped or dragged and must be stored on wooden cribbing. If, in the opinion of the engineer, the coated bars have been extensively damaged, the material will be rejected. The contractor may propose for the approval of the engineer, alternate precautionary measures.

6.2 Fabrication and Placement. The bars shall be fabricated and placed as shown on the plans and as specified. All bending should be done around nylon coated pins or wooden mandrels. The rate of bending may have to be reduced for some bar sizes to minimize cracking or disbonding of the coating. Any visible evidence of cracking or disbonding of the coating in the bent area of bars bent in accordance with the plan requirements may be patched with approval of the engineer, except that a hairline crack, 0.003 inch or less, at the base of the deformation will not be cause for rejection nor will patching of these cracks be required. All patching shall be done promptly after bending. Bars shall not be shipped until patching material has lost all tackiness.

Plastic-coated tie wires approved by the engineer shall be used in the assembly of the coated bars in the structure to protect them from physical damage.

6.3 Patching. Patching material shall be applied to all sheared ends and contact areas for hangers or couplers. Patching materials shall be applied to all damaged areas at the points of occurrence, such as the initial application, fabrication, destination or installation points with the following exception. Damaged areas of coating not more than 0.2 inch across at the widest point of exposed area of bare steel and occurring no more than six in any lineal foot of coated bar need not be repaired.

Areas to be patched shall be clean and free of surface contaminants. They shall be promptly treated in accordance with the resin manufacturer's recommendations and before detrimental oxidation occurs.

## 7. MIXING

7.1 Job-Mixed Concrete: The equipment used for mixing concrete on the project site shall be capable of combining the aggregates, cement and water into a thoroughly mixed and uniform mass, and of discharging the mixture without segregation. The concrete shall be mixed in quantities required for immediate use. Concrete shall not be used which has developed its initial set or that has not been placed within one-half (1/2) hour after the water has been added. Retempering concrete by adding water or by any other means will not be permitted.

The concrete shall be mixed not less than sixty seconds. When a double compartment mixer is used, the minimum mixing time in the first compartment shall be thirty seconds and the total mixing time, including transfer time, shall not be less than sixty-five seconds.

Concrete may be mixed by a paving mixer into which the materials, including the water, can be precisely and regularly proportioned, and which will produce a concrete of uniform consistency, uniform color, and thoroughly and uniformly mixed. The paving mixer shall be equipped with a batch meter and an automatic locking timing device. The water tank shall be equipped with a scale graduated in gallons and fractions thereof. The water measuring device shall be capable of accurate measurement to within one percent of the required amount. The paving mixer shall be equipped with a boom and bucket, fully power controlled, which shall be so operated that the batches may be uniformly distributed on the subgrade.

**7.2 Ready-Mixed Concrete:** Ready-Mixed (Transit-mixed) concrete may be used in lieu of concrete mixed at the project site. When used, transit-mixed concrete shall comply with the applicable provisions of Division 150, Equipment and Division 400, Portland Cement Concrete of the Standard Specifications for State Road and Bridge Construction, 1990 Edition, Kansas Department of Transportation, except that testing will be in accordance with the requirements of "Control Tests" in this Section.

## 8. PLACING CONCRETE

**8.1 General:** Before beginning placement of concrete, hardened concrete and foreign materials shall be removed from the inner surface of the conveying equipment. Before depositing concrete, all debris shall be removed from the space to be occupied by the concrete; forms, if constructed of lumber, shall be thoroughly wetted (except in freezing weather) or oiled. Reinforcement shall be secured thoroughly in position and approval by the Engineer obtained before concrete is placed.

**8.2 Removal of Water:** Water shall be removed from the space to be occupied by the concrete before concrete is deposited, unless otherwise directed by the Engineer. Any flow of water into an excavation shall be diverted through proper side drains to a sump, or be removed by other approved methods which will avoid washing the freshly deposited concrete. If directed by the Engineer, water vent pipes and drains shall be filled by grouting, or other approved means, after the concrete has thoroughly hardened.

**8.3 Handling:** Concrete shall be handled from the mixer, or in the case of ready-mixed concrete from the transporting vehicle, to the place of final deposit as rapidly as practicable by methods which shall prevent the separation or loss of the ingredients. Under no circumstances shall partially hardened concrete be deposited in the work. Concrete shall be deposited in the forms as nearly as practicable in its final position to

avoid rehandling. It shall be deposited as to maintain, until the completion of the unit, an approximately horizontal plastic surface. Forms for walls or thin sections of considerable height shall be provided with openings or other devices that will permit the concrete to be placed in a manner that will prevent segregation and accumulations of hardened concrete on forms or metal reinforcement above the level of concrete. Regardless of the type of transporting vehicle, concrete shall have the quality required when deposited in the forms.

**8.4 Chuting:** When concrete is conveyed by chutes, the equipment shall be of such size and design as to insure a continuous flow in the chute. Chutes shall be of metal or metal lined and the different portions shall have approximately the same slope. The slope shall not be less than one vertical to two horizontal and shall be such as to prevent segregation of the ingredients. The discharge end of the chute shall be provided with a baffle plate to prevent segregation. If the distance of the discharge end of chute above surface of the concrete is more than 3 times the thickness of the layer being deposited, but not more than 5 feet above surface of concrete, a spout shall be used and the lower end maintained as near the surface of deposit as practicable. When the operation is intermittent, the chute shall discharge into a hopper. The chute shall be thoroughly cleaned before and after each run and all debris and cleaning water shall be discharged outside the forms.

**8.5 Compacting:** During and immediately after depositing, concrete shall be compacted thoroughly by means of suitable tools. In general, concrete shall be compacted by mechanical vibration. Number and type of vibrators shall be subject to the approval of the Engineer.

For thin walls or inaccessible portions of forms where spading, rodding, or forking is impracticable, concrete shall be worked into place by vibrating or tapping forms lightly opposite the freshly deposited concrete. Concrete shall be worked thoroughly around reinforcement, and around embedded fixtures, and into corners of forms.

Accumulations of water on surface of concrete, during placement and compacting, due to water gain, segregation or other causes shall be prevented as far as possible by adjustments in the mixture. Provisions shall be made for removal of such water as may accumulate so that, under no circumstances, will fresh concrete be placed in such accumulations.

**8.6 Depositing Continuously:** Concrete shall be deposited continuously or in layers of such thickness that no fresh concrete will be deposited on concrete which has hardened sufficiently to cause formation of seams and planes of weakness within the section. If a section cannot be placed continuously, construction joints shall be located at points as provided for in the drawings or approved by the Engineer.

8.7 Depositing in Cold Weather: Concrete when deposited shall have a temperature of not less than 50° F. nor more than 100° F. The Contractor shall submit for the approval of the Engineer the methods he proposes to use for protecting the concrete from freezing temperatures during the first 72 hours where Type I or II Portland cement is used, or 24 hours where Type III (high early strength) Portland cement is used.

Before placing concrete, forms or subgrade shall be free from frost and ice. Methods of heating materials shall be approved by the Engineer. Salts, chemicals or other foreign materials shall not be mixed with the concrete for the purpose of preventing freezing. Calcium Chloride may be used as an accelerator when specifically approved by the Engineer.

8.8 Bonding: Before depositing fresh concrete on or against concrete which has hardened, forms shall be retightened. The surface of the hardened concrete shall be roughened, in a manner that will not leave loosened particles of aggregate or damaged concrete at the surface, cleaned thoroughly of foreign matter and saturated with water. To provide adequate mortar at the juncture of the hardened and newly deposited concrete, the cleaned and saturated surfaces, including vertical and inclined surfaces, shall be first covered thoroughly with a coating of mortar or neat cement grout, against which new concrete shall be placed before the grout has attained its initial set.

8.9 Wet Pour Method: When approved by the Engineer, the Contractor may place a wet pour if he cannot prevent the flow of water into the area as defined in 8.2. At the time a wet pour is made the water level shall be static and below the concrete form surface elevation, unless approved otherwise by the Engineer. A wet pour shall be placed by the tremie method or by pump after the reinforcing and forms are determined to be acceptable by the Engineer. A tremie shall consist of a watertight tube having a diameter of not less than 10 inches with a hopper at the top. When a batch is dumped into the hopper, the flow of concrete shall be induced by slightly raising the discharge end, always keeping it in the deposited concrete.

Concrete pump discharge tubes and tremie tubes used to deposit concrete in water shall be equipped with a device that will prevent water from entering the tube while charging the tube with concrete. Such tubes shall be supported so as to permit free movement of the discharge end over the entire top surface of the work and to permit rapid lowering, when necessary to control or stop the flow of concrete. The tubes shall be filled by a method that will prevent washing of the concrete. The discharge end shall be completely submerged in concrete at all times and the tube shall contain sufficient concrete to prevent any water entry. The flow shall be continuous until the work is completed and the resulting concrete seal shall be monolithic and homogeneous. The wet pour shall be placed in one continuous pour until the form is filled to the plan elevation and all water and unsound concrete has been removed.

When requested by the Engineer the method selected by the Contractor to place the concrete shall be submitted for approval along with sufficient details and data to review the procedure. Concrete for a wet pour shall be the same class of concrete as specified on the plans with a minimum of 10% additional cement and a slump not to exceed six (6) inches.

#### 9. CURING OF CONCRETE

All concrete surfaces shall be protected to insure that loss of moisture from the surface is held to a minimum for a period of at least seven (7) days following initial set. Where Type III (high early strength) Portland cement is used, the period shall be not less than three (3) days. Concrete damaged by improper curing shall be subject to removal and replacement as directed. The method of curing, regardless of type, will not relieve the Contractor of his responsibility to provide concrete having required strength and surface finish. Unless otherwise specified for a specific item of work, the prevention of the loss of moisture from the concrete surface shall be accomplished by one of the following alternate methods:

- a. Surface maintained continuously wet by sprinkling or inundation;
- b. Covering with burlap mats kept continuously wet;
- c. Covering surfaces with white or translucent polyethelene sheeting not less than .004 inch in thickness. Splices shall be made with a minimum lap of 4 inches and sealed with adhesive tape approved by the Engineer;
- d. Application of a membrane curing compound such as Protex Industries "Triple Seal"; Carter-Waters' "Chlorcure"; or an equal product approved by the Engineer. Application shall be at a rate of not more than 200 square feet of surface per gallon of compound;
- e. Forms left in place during the specified curing period shall be sprinkled and maintained moist as required to prevent rapid drying of the concrete;
- f. Other methods of curing as may be approved by the Engineer.

#### 10. CONTROL TESTS

All concrete and concrete materials used in the work shall be tested as directed by the Engineer. The Contractor shall provide material for all samples and test specimens required.

So long as the Contractor's work progresses in an orderly and reasonable manner the costs of field sample preparation and testing of all specimens will be borne by the Owner. Should the Contractor use methods or procedures that require unreasonable or excessive field testing to determine whether specification requirements are being met, or if field testing is performed with continued negative results that indicate the



Contractor's methods or procedures are not adequate to provide the specified results, the Engineer shall notify the Contractor in writing that the costs of all additional testing beyond specific limits, which shall be set out in the written notice for the particular area or material in question, shall be the responsibility of the Contractor. Such costs will then be deducted from the monies due the Contractor for the work performed.

Control tests which will be conducted on a continuing basis include:

10.1 Slump Test: (ASTM-C143) as directed during concrete placement.

10.2 Yield Test: (ASTM-C138) as directed during concrete placement, generally once each day during concrete placement.

10.3 Compressive Strength: (ASTM-C39) two (2) test specimens for each 50 cubic yards or less of each class of concrete placed during one days operation to be tested at 7 and 28 days. Test specimens to be prepared in accordance with ASTM-C31.

10.4 Flexural Strength: (ASTM-C78) as directed during concrete placement, generally two (2) test specimens for each days placement of more than 50 CY. Test specimens to be prepared in accordance with ASTM-C31.

10.5 Air Entrainment: (ASTM-C231) as directed during concrete placement, generally at least once each day during concrete placement.

## 11. DEFECTIVE CONCRETE

11.1 Deficient Strength: Where the results of strength tests indicate concrete which fails to conform to these specifications, additional test specimens shall be taken, in accordance with ASTM C42, from the questioned areas, as directed by the Engineer. If the strength indicated by these core samples meets the specification requirements the concrete will be accepted. In the event that the core tests fail to meet the specifications, all concrete represented by the deficient test specimen shall be removed and replaced by the Contractor at no additional cost to the Owner. The cost of all coring and testing, including satisfactory patching of core holes, shall be borne by the Contractor.

11.2 Defective Area: Areas of concrete which are defective for reasons other than strength (i.e. Honeycombs, finish irregularities, misalignment of forms, etc.) shall be repaired by methods approved by the Engineer. When in the opinion of the Engineer satisfactory repairs cannot be made the defective concrete shall be removed and replaced by the Contractor at no additional cost to the Owner.

## 12. CONSTRUCTION

12.1 General: The Contractor shall ensure all pipe, pipe sleeves, reinforcing and other embedments are properly set and placed prior to any concrete pours. Concrete items shall be constructed to the detailed thickness and to the lines and grade as shown on the plans. Concrete shall be placed over moistened and unfrozen subgrade and when the ambient temperature is 40°F or greater and rising. The subgrade shall be void of excessive moisture. The concrete shall be reinforced with the type of reinforcement indicated and the reinforcement shall be secured and tied in place prior to depositing any concrete.

12.2 Expansion Joints: Asphalt Expansion Joints shall be composed of asphalt, vegetable fibres, and mineral fillers, formed under heat and pressure between two asphalt-saturated felt liners. Asphalt Expansion Joints shall conform to AASHTO M33 or ASTM D994, shall be 1/2" thick and weigh approximately 3 pounds per square foot, unless shown otherwise on the plans.

12.3 Waterstop: Waterstop shall be extruded P.V.C. material with multiple ribs and center bulb for construction joints. It shall be 4-7/16" wide and 3/16" thick (min.). P.V.C. waterstop for expansion joints shall be 3/16" thick (min) and be designed for 1/2" expansion (min). The waterstops shall be Labyrinth Model B3 as manufactured by Water Seals, Inc., Chicago, Illinois, phone 1-312-332-6765 or approved equal.

12.4 Joint Sealer: After the specified curing period, the faces of all joints to be sealed shall be thoroughly cleaned, using compressed air, sweeping, brooming or other methods approved by the Engineer. The faces of the joint shall be dry after being thoroughly cleaned, and filled with joint sealing compound using a nozzle designed to completely fill the joint.

Joints shall be filled to within the top surface, but in no case shall they be overfilled. Upon completion of the joint sealing operations, all excess material and foreign material shall be removed from the concrete surface.

Joint Sealant to be polysulfide base which cures to a flexible seal with good bonding characteristics or as shown otherwise in the plans.

12.5 Finishing of Related Unformed Surface: Surfaces to receive concrete Class III (grout) or equipment foundations shall have a rake finish or broom finish. Equipment or structure foundations, floor slabs and steps not to receive concrete Class III (grout) shall receive a troweled finish. Slabs to receive a coating shall have a finish as recommended by coating manufacturer.

Sidewalks shall receive a light broomed finish.

12.6 Finishing of Formed Surfaces: All surfaces exposed to view which have been in contact with the forms shall receive a smooth rubbed finish in accordance with Section 10.3.1 of ACI 301-72 after the surfaces have been prepared as specified in Chapter 9 of ACI 301-72. All air bubbles shall be filled with a bonding grout and rubbed down with sacks before final rubbing as specified above. This shall include all exposed edges and surfaces of walls.

## **DIVISION 17 - PROCESS PIPING**

### **SECTION 17102 - GATE VALVE (RESILIENT SEAT)**

#### **1. MANUFACTURERS**

AVK Series 25 or approved equal.

#### **2. GENERAL**

Gate valve shall be designed for a working pressure of not less than 150 pounds per square inch and shall meet AWWA C500 requirements. Valves shall have mechanical joints for the piping in which they are installed. Valves shall have a smooth unobstructed waterway as large as the inside pipe diameter it is intended for. Valves shall have a non-rising stem, be equipped with an operating nut and be opened by turning counter clockwise. Valve shall be iron bodied with epoxy coating and be equipped with a bubble tight synthetic coated cast iron disc.

One operating key shall be furnished to the Owner for operation of the valve.

Valve boxes shall be cast iron construction with screwed extension sleeve. Minimum thickness of boxes shall be 3/16" with a diameter as shown in the plans. Valve box lids shall have "Water" cast into the lid.

## SECTION 17108 - TAPPING SLEEVES AND TAPPING VALVES

### 1. MANUFACTURE

Mueller H-615 (Sleeve) and H-667 (Valve) or approved equal.

### 2. TAPPING SLEEVE

Tapping sleeve shall be a cast iron mechanical joint type supplied with the proper end gaskets to fit the type and class of pipe intended. Contractor is to verify the pipe size and class prior to ordering the tapping sleeve. The tapping sleeve shall have a minimum rated working pressure of 200 PSIG. Sleeve shall be coated with manufacturers standard coating.

### 3. TAPPING VALVE

Tapping valve shall be a resilient seat non-rising stem gate valve with flange end to mate to the tapping sleeve and a mechanical joint end to connect the pipe. Inlet flange shall be Class 125 (ASA B16.1), with the outlet having a mechanical joint connection (ANSI A21.11). The Mechanical joint end is to have slotted bolt holes that fit a standard tapping machine. The valve is to have a minimum rated working pressure of 150 PSIG. (See Section 17102 for material specifications on valve and valve box.)

### 4. INSTALLATION

The tapping assembly is to be installed level and with proper support. The tap is to be made full size by a factory authorized representative with the proper equipment. The tap shall be tested to the minimum rated working pressure.

## SECTION 17270 - BUTTERFLY VALVE

### 1. MANUFACTURERS

Pratt, or approved equal.

### 2. GENERAL

The butterfly valves shall be AWWA Class 150B. Ends to be flanged and shall be suitable for installation between ANSI Class 125 or Class 150 flanges. Valves shall be suitable for Bi-Directional service.

### 3. MATERIALS OF CONSTRUCTION

- A. Shaft Bearing Surfaces and Packing. Sizes 2" to 20", Nylon, Reinforced Teflon. Sizes 24" to 48", Reinforced Teflon. Shaft seals shall be provided with a minimum of three rings of chevron v-type self-adjusting packing. O-rings not acceptable.
- B. Bodies. Cast Iron ASTM A-126 Class B, or Ductile Iron ASTM A-536 Grade 65-45-15. Port diameter shall be within one inch of nominal valve size. Stops in the valve body are not acceptable.
- C. Discs. Cast Iron ASTM A-126 Class B, or Ductile Iron ASTM A-536 Grade 65-45-12.
- D. Shafts. Stainless Steel Type 304 or Type 316.
- E. Seats. Seats shall be synthetic rubber compound and body mounted. Natural rubber is not acceptable. Mating seat surfaces shall be type 316 stainless steel or plasma applied nickel chrome.
- F. Shaft to Disc Connection. This connection shall be made with stainless steel dowel or taper pins extending through both sides of the shaft and disc.

### 4. PNEUMATIC CYLINDER OPERATORS

Cylinder operators shall move the valve to any position from full open to fully closed with a maximum of 100 psi or a minimum of 60 psi applied to the cylinder. All internal parts of the cylinder shall be non-metallic, except the cylinder rod which shall be chromium plated stainless steel. Piston seals shall be of the non-adjustable, wear-compensating type. O-rings are not acceptable.

Rod seals shall be of the non-adjustable, wear-compensating type. O-rings are not acceptable. A rod wiper for removing deposits inside the cylinder shall be provided in addition to the external dirt wiper.

Cylinder accessories shall be as follows without exception and shall be factory mounted on the valve.

- A. Asco 8342 or 8344 4-way solenoid valve with manual override.
- B. Manual handwheel override and bleed cocks to open and close the valve in the event of a compressed air outage.
- C. Open and closed limit switches, Square D Type 9007 or Allen Bradley 802T.
- D. Speed controls, Parker Hannifin or Manatrol.

#### 5. PNEUMATIC CYLINDER OPERATORS WITH POSITIONERS

Pneumatic cylinder operators shall be provided with limit switches, manual override and floor positioners. Cylinder operators shall be as specified in (4). The following accessories shall be provided without exception and shall be factory mounted on the valve.

- A. Bailey AP-4 or Pratt Roto-Positioner.
- B. Manual handwheel override and bleed cocks to open and close the valve in the event of a compressed air outage.
- C. Open and closed limit switches, Square D Type 9007 or Allen Bradley 802T.

#### 6. GEAR OPERATOR

Manual operators shall be of the traveling nut or worm gear type and shall be designed to hold the valve in any intermediate position between fully open and fully closed without creeping or fluttering. Operators shall be equipped with mechanical stop-limiting devices inside the operator to prevent overtravel of the disc in the open and closed positions. Valves shall close with a clockwise rotation. Operators shall be fully enclosed with a removable cover to permit inspection and adjustment of the mechanism and shall be designed to produce the specified torque with a maximum pull of 80 lb. on the handwheel or chainwheel. Operator components shall withstand an input of 300 Ft. Lbs. at extreme operator position without damage. Manual operators shall be Pratt MDT or Limitorque HB without exception.

#### 8. TESTS

Certified copies of leak, hydro, and proof of design tests as required by AWWA C504 shall be submitted to the engineer at the time of valve shipment.

9. SPECIAL CONDITIONS

Manual valves shall be readily adaptable to the installation of cylinder or electrical motor operator. All operators and cylinders on the 12" and 14" valves shall be the same size. Operators on the 4" and 6" valves shall be the same size.

10. PAINTING

Valves shall be painted in accordance with AWWA C504. Finish coat with epoxy.



## SECTION 17535 - FIRE HYDRANT ASSEMBLY

### 1. MANUFACTURERS

Mueller Centurion A-423 or approved equal.

### 2. GENERAL

Fire Hydrant Assembly shall include all material and labor to furnish the assembly complete in place.

The fire hydrants supplied shall include a 2-2 1/2" National Standard fire hose thread connections and one National Standard pumper connection. Hydrants are to have a 5 1/4" net valve opening and a 6" mechanical joint inlet connection. Hydrant bury as required by contract plans or as required to provide a minimum cover of 42 inches over top of water main. Operating nut to be National Standard pentagonal nut. Direction of opening to be to left (counter-clockwise). Hydrants are to be painted silver.

### 3. FIRE HYDRANT ASSEMBLY COMPONENTS

The Fire Hydrant assembly shall include the following: the hydrant valve anchor tee, the 6" MJ gate valve, the 6" valve box, 6" mechanical joint anchor coupling, the fire hydrant, all hydrant barrel extensions required to bring the fire hydrant to grade, and all concrete thrust blocking required for the hydrant tee and fire hydrant.

All threads and connectors to be reviewed with City.

### 4. SETTING OF FIRE HYDRANTS

Fire hydrants shall be located and installed as shown on the plans. Hydrants shall be set according to the requirements of AWWA C600 except as specifically amended in the plans or specifications. Each hydrant shall be set to stand plumb and shall be oriented such that immediate access is provided.

